

FM250G
Broadcast Transmitter

User's Manual

Revision Control

Revision

Print Date

Rev A

September 2002

Important Notices

©2002 International Radio and Electronics, Inc.

Portions of this document were originally copyrighted by Michael P. Axman in 1991.

All rights reserved. No part of this publication may be reproduced, transmitted, transcribed, stored in a retrieval system, or translated into any language in any form by any means without the written permission of Crown International, Inc.

Printed in U.S.A.

Sony and RCA are trademarks of their respective companies.

IREC attempts to provide information that is accurate, complete, and useful. Should you find inadequacies in the text, please send your comments to the following address:

International Radio and Electronics
25166 Leer Drive, P.O. Box 2000
Elkhart, Indiana, 46515-2000 U.S.A.

Table of Contents

Section 1—Getting Acquainted

1.1	Your Transmitter	1-2
1.2	Applications and Options	1-3
1.2.1	Stand-Alone.....	1-4
1.2.2	Backup	1-4
1.2.3	Booster.....	1-4
1.2.4	Exciter	1-4
1.2.5	Translator	1-5
1.2.6	Satellator	1-6
1.2.7	Nearcasting	1-6
1.3	Transmitter/Exciter Specifications	1-7
1.4	Receiver Specifications.....	1-8
1.5	Safety Considerations.....	1-9
1.5.1	Dangers.....	1-9
1.5.2	Warnings.....	1-9
1.5.3	Cautions	1-9

Section 2—Installation

2.1	Operating Location	2-2
2.2	Power Connections.....	2-2
2.3	Frequency (Channel) Selection	2-4
2.3.1	Modulation Compensator	2-5
2.3.2	RF Tuning Adjustments	2-5
2.4	Receiver Frequency Selection	2-6
2.5	RF Connections	2-8
2.6	Audio Input Connections	2-9
2.7	SCA Input Connections	2-10
2.8	Composite Input Connection	2-10
2.9	Audio Monitor Connections	2-11
2.10	Pre-emphasis Selection	2-11
2.11	Processor Bypass Option	2-11
2.12	Program Input Fault Time-out	2-12
2.13	Remote I/O Connector	2-12

Section 3—Operation

3.1	FM250G Initial Power-up Procedures	3-2
3.1.1	Power Switch	3-3
3.1.2	Carrier Switch.....	3-3
3.2	Front Panel Bar-Dot Displays.....	3-4
3.2.1	Audio Processor Input.....	3-4
3.2.2	Highband and Wideband Display.....	3-4
3.2.3	Modulation Display.....	3-4
3.3	Input Gain Switches.....	3-5
3.4	Processing Control	3-5
3.5	Stereo-Mono Switch.....	3-5

3.6	RF Output Control	3-6
3.7	Digital Multimeter	3-6
3.8	Fault Indicators	3-7

Section 4—Principles of Operation

4.1	Part Numbering	4-2
4.2	Audio Processor Circuit Board.....	4-2
4.3	Stereo Generator Circuit Board.....	4-4
4.4	RF Exciter Circuit Board.....	4-5
4.5	Metering Circuit Board.....	4-6
4.6	Motherboard.....	4-8
4.7	Display Circuit Board	4-8
4.8	Voltage Regulator Circuit Board.....	4-9
4.9	Power Regulator Circuit Board	4-10
4.10	RF Driver	4-11
4.11	RF Amplifier.....	4-11
4.12	Chassis and AC Supply.....	4-11
4.13	RF Output Filter & Reflectometer.....	4-12
4.14	Receiver Circuit Board Option.....	4-12

Section 5—Adjustments and Tests

5.1	Audio Processor Adjustments	5-2
5.1.1	Pre-Emphasis Selection	5-2
5.1.2	Pre-Emphasis Fine Adjustment	5-2
5.2	Stereo Generator Adjustments.....	5-2
5.2.1	Separation.....	5-2
5.2.2	Composite Output	5-2
5.2.2.1	Using a Modulation Monitor	5-2
5.2.2.2	Using Bessel Nulls.....	5-3
5.2.3	19-kHz Level.....	5-3
5.2.4	19-kHz Phase.....	5-3
5.3	Frequency Synthesizer Adjustments.....	5-3
5.3.1	Frequency Channel Selections.....	5-3
5.3.2	Modulation Compensator	5-4
5.3.3	Frequency Measurement and Adjustment	5-4
5.3.4	FSK Balance Control.....	5-4
5.4	Metering Board Adjustments	5-4
5.4.1	Power Calibrate	5-4
5.4.2	Power Set.....	5-4
5.4.3	SWR Calibrate.....	5-5
5.4.4	PA Current Limit.....	5-5
5.5	Motherboard Adjustments	5-5
5.6	Display Modulation Calibration	5-5
5.7	Voltage Regulator Adjustments	5-5
5.8	Performance Verification	5-6
5.8.1	Audio Proof-of-Performance Measurements.....	5-6
5.8.2	De-emphasis Input Network.....	5-6
5.9	Carrier Frequency	5-6
5.10	Output Power.....	5-6

5.11 RF Bandwidth and RF Harmonics	5-7
5.12 Pilot Frequency	5-7
5.13 Audio Frequency Response	5-7
5.14 Audio Distortion.....	5-7
5.15 Modulation Percentage	5-7
5.16 FM and AM Noise	5-7
5.17 Stereo Separation	5-8
5.18 Crosstalk.....	5-8
5.18.1 Main Channel Into Sub	5-8
5.18.2 Sub Channel Into Main	5-8
5.19 38-kHz Subcarrier Suppression	5-8
5.20 Additional Checks	5-8

Section 6—Reference Drawings

6.1 Views	6-2
6.2 Board Layouts and Schematics	6-4
Audio Processor	6-5
Stereo Generator	6-7
RF Exciter	6-9
Metering	6-11
Motherboard.....	6-13
Display.....	6-15
Voltage Regulator	6-17
Power Regulator	6-19
RF Output Amplifier	6-21
Quadrature Power Combiner	6-22
RF Input.....	6-23
DC Input	6-24
RF Output Filter and Reflectometer	6-26
FM Predriver	6-28
Chassis Wiring.....	6-29
Receiver Board	6-31

Section 7—Service and Support

7.1 Service.....	7-2
7.2 24-Hour Support.....	7-2
7.3 Spare Parts.....	7-2

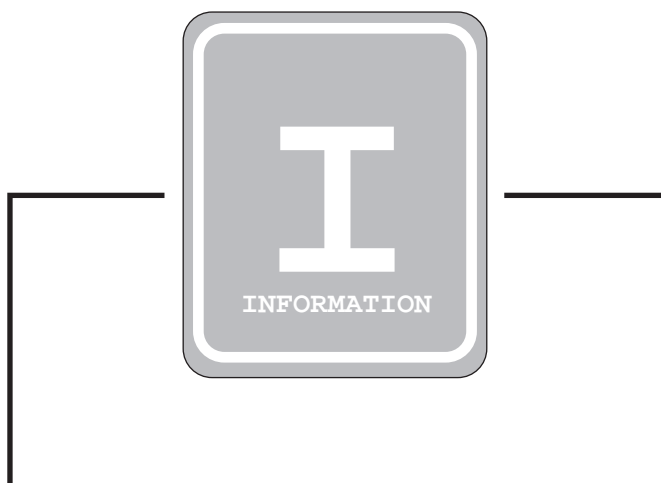

Section 1—Getting Acquainted

This section provides a general description of the FM250G transmitter and introduces you to safety conventions used within this document. *Review this material before installing or operating the transmitter.*

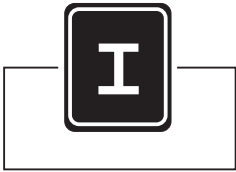

1.1 Your Transmitter

The FM250G is a member of a family of FM stereo broadcast transmitters. Crown transmitters are known for their integration, ease-of-use, and reliability.

The integration is most apparent in the standard transmitter configuration which incorporates audio processing, stereo generation, and RF amplification without compromised signal quality. A single Crown transmitter can replace several pieces of equipment in a traditional system.

Ease-of-use is apparent in the user-friendly front panel interface and in the installation procedure. Simply select your operating frequency add an audio source, attach an antenna, and connect AC power and you're ready to broadcast. Of course, the FM series of transmitters also feature more sophisticated inputs and monitoring connections if needed.

Reliability is a Crown tradition. The first Crown transmitters were designed for rigors of worldwide and potentially portable use. The modular design, quality components, engineering approach, and high production standards ensure stable performance. For more direct monitoring, the front panel includes a digital multimeter display and status indicators. Automatic control circuitry provides protection for high VSWR as well as high current, voltage, and temperature conditions.

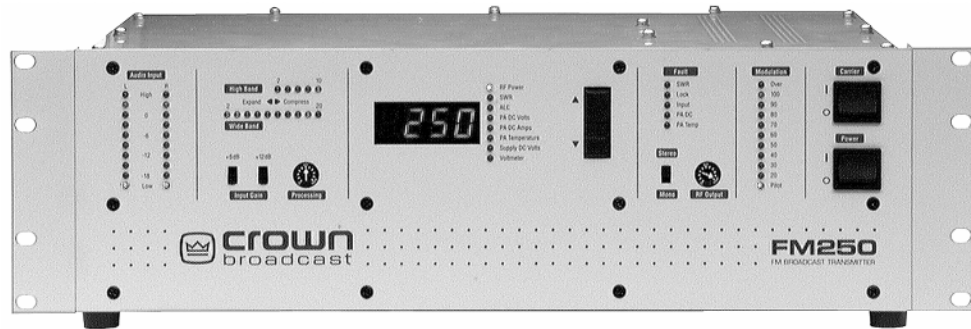

Illustration 1-1 FM250G FM Broadcast Transmitter

1.2 Applications and Options

Crown transmitters are designed for versatility in applications. They have been used as stand-alone and backup transmitters and in booster, translator, satellator, and nearcast applications. The following discussion describes these applications further.

Model numbers describe the configuration of the product (which has to do with its intended purpose) and the RF output power which you can expect.

The number portion of each name represents the maximum RF output power. The FM250G, for example, can generate up to 250 watts of RF output power.

Suffix letters describe the configuration. The FM250GT, for example, is the standard or transmitter configuration. Except where specified, this document describes the transmitter configuration. In this configuration, the product includes the following components (functions):

- audio processor
- stereo generator
- RF exciter
- metering
- low-pass filter

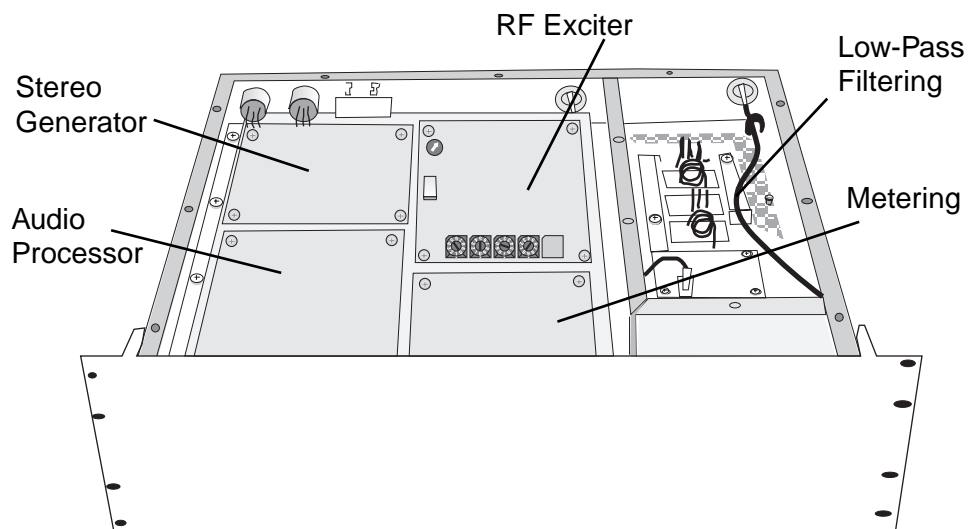
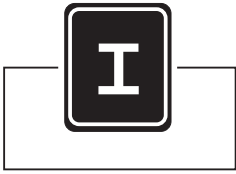

Illustration 1-2 Standard (Transmitter) Configuration



1.2.1 Stand-Alone

In the standard configuration, the FM250G is an ideal stand-alone transmitter. When you add an audio source (monaural, L/R stereo, or composite signal), an antenna, and AC power, the transmitter becomes a complete FM stereo broadcast station, capable of serving a community.

As stand-alone transmitters, Crown units often replace multiple pieces of equipment in a traditional setup (exciter, audio processor, RF amplifier).

1.2.2 Backup

In the standard configuration, Crown transmitters are also used in backup applications. Should your primary transmitter become disabled, you can continue to broadcast while repairs take place. In addition, the FM transmitters can replace disabled portions of your existing system including the exciter, audio processor, or amplifier. Transfer switches on each side of the existing and backup transmitters make the change-over possible with minimal downtime.

1.2.3 Booster

Also in the standard configuration, Crown transmitters have been used as booster transmitters. Booster applications typically involve certain geographic factors which prevent your system from broadcasting to the full coverage area allowable. For example, a mountain range might block your signal to a portion of your coverage area. Careful placement of a Crown transmitter, operating on the same frequency as your primary transmitter, can help you reach full coverage. An external receiver and special antenna are required to use Crown FM transmitters as boosters.

1.2.4 Exciter

In addition to the standard configuration, Crown FM transmitters are available in optional configurations to meet a variety of needs.

An “E” suffix, as in the FM30GE, for example, represents an exciter-only configuration. In this configuration, the audio processor and stereo generator boards are replaced with circuitry to bypass their function. The exciter configurations are the least expensive way to get Crown-quality components into your transmission system.

You might consider the Crown exciter when other portions of your system are performing satisfactorily and you want to maximize your investment in present equipment.

1.2.5 Translator

The FM30GR receiver option replaces the audio processor and stereo generator boards with a receiver module. This added feature makes Crown transmitters ideal for translator service in terrestrial-fed networks. These networks represent a popular and effective way to increase your broadcasting coverage. Translators, acting as repeater emitters, are necessary links in this chain of events.

Traditionally, network engineers have relied on multiple steps and multiple pieces of equipment to accomplish the task. Others have integrated the translator function (receiver and exciter) to feed an amplifier. Crown, on the other hand, starts with an integrated transmitter and adds a solid-state Receiver Module to form the ideal translator.

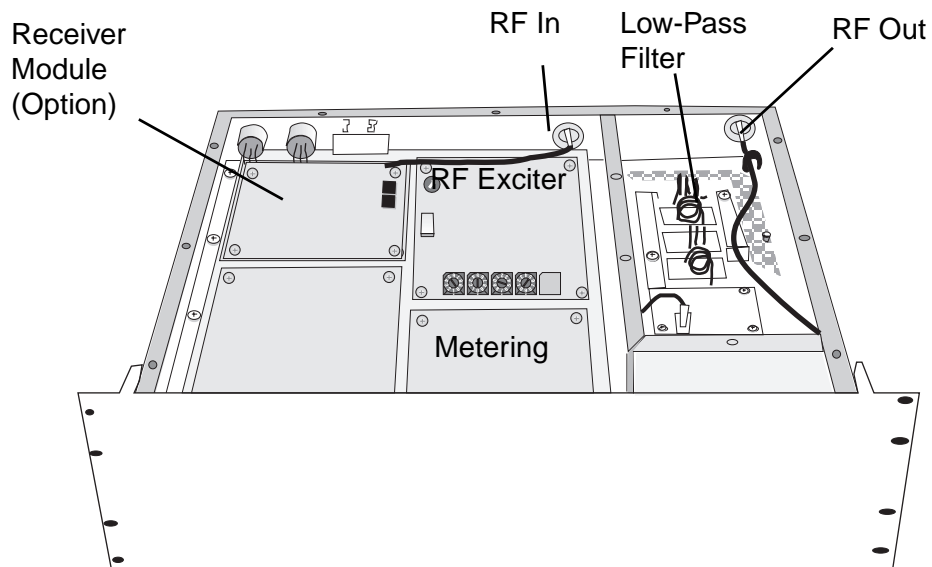
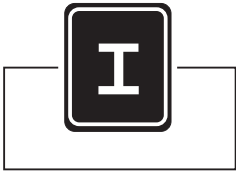

Illustration 1-3 Crown's Integrated Translator

This option enables RF in and RF out on any of Crown's FM series of transmitters. In addition, the module supplies a composite output to the RF exciter portion of the transmitter. From here, the signal is brought to full power by the built-in power amplifier for retransmission. The Receiver Module has been specifically designed to handle SCA channel output up to 100 kHz for audio and high-speed data.

FSK ID programming is built-in to ensure compliance with regulations regarding the on-air identification of translators. Simply specify the call sign of the repeater station when ordering. Should you need to change the location of the translator, replacement FSK chips are available. The Receiver Module option should be ordered at the time of initial transmitter purchase. However, an option kit is available for field converting existing Crown units.

In the translator configuration there are differences in the function of the front panel, See Section 3.7, Digital Multimeter for a description.



1.2.6 Satellator

Crown transmitters include automatic call sign or operating frequency transmission in a Morse code style. This feature is intended for use in satellite-fed networks. Transmitters equipped in this fashion are often known as “satellators.”

Connect the transmitter to your satellite receiver and the built-in FSK IDer does the rest—shifting the frequency in a manner that is unnoticeable to the listener.

1.2.7 Nearcasting

Some Crown units function as “nearcast” transmitters. Their low-power output is not designed for broadcasting a signal but for transmitting it to local receivers, sometimes within the same room. Crown transmitters have been used in this way for language translation, for rebroadcasting the audio of sporting events within a stadium, and for specialized local radio. Crown makes a dedicated nearcast transmitter. However, the FM250G is also appropriate for this application.

1.3 Transmitter/Exciter Specifications

Frequency Range	87-108 MHz
RF Power Output	(VSWR 1.5:1 or better) 50-250 watts, adjustable
RF Output Impedance	50 Ω
Audio Input Impedance	50 k Ω bridging, balanced, or 600 Ω
Audio Input Level	Selectable for -10 dBm to +10 dBm for 75 kHz deviation at 400 Hz
Pre-emphasis	Selectable for 25, 50, or 75 μ sec; or Flat
Audio Response	Conforms to 75 μ sec pre-emphasis curve as follows
Complete transmitter	\pm 0.30 dB (50 Hz-10 kHz) \pm 1.0 dB (10 kHz-15 kHz)
Exciter only	\pm 0.25 dB (50 Hz-15 kHz)
Distortion (THD + Noise)	
Complete transmitter	Less than 0.7% (at 15 kHz)
Exciter only	Less than 0.3% (50 Hz-15 kHz)
Stereo Separation	
Complete transmitter	Better than -40 dB (50 Hz-15 kHz)
Exciter only	Better than -40 dB (50 Hz-15 kHz)
Crosstalk	Main into sub, better than -40 dB Sub into main, better than -40 dB
Stereo Pilot	19 kHz \pm 2 Hz, 9% modulation
Subcarrier Suppression	50 dB below \pm 75 kHz deviation
FM S/N Ratio (FM noise)	
Complete transmitter	Better than -60 dB
Exciter only	Better than -70 dB
RF Bandwidth	\pm 120 kHz, better than -35 dB \pm 240 kHz, better than -45 dB
RF Spurious Products	Better than -70 dB

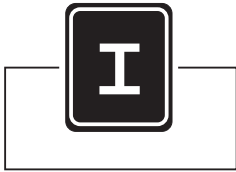

Rev A

Operating Environment	Temperature (0° C -50° C) Humidity (0-80% at 20° C) Maximum Altitude (3,000 meters; 9843 feet)
AC Power	90-264 volts; 650 VA at 120 or 240 volts AC
Note: Note: We set voltage and ampere requirements to assist you in designing your system. Depending on your operating frequency, actual requirements for maximum voltage and current readings are 10-15% lower than stated.	
Regulatory	Meets CE and TUV requirements
Dimensions	13.5 x 41.9 x 44.5 cm (5.25 x 16.5 x 17.5 inches)
Weight	13.6 kg (30 lbs) shipping weight

1.4 Receiver Specifications

Monaural Sensitivity (demodulated, de-emphasized)	3.5 μ V for signal-to-noise > 50 dB 12.6 μ V for signal-to-noise > 60 dB
Stereo Sensitivity (19-kHz pilot frequency added)	2.8 μ V for signal-to-noise > 40 dB 8 μ V for signal-to-noise > 50 dB 31 μ V for signal-to-noise > 60 dB
Connector	Standard type N, 50 Ω
Shipping Weight	1 lb

1.5 Safety Considerations

Crown Broadcast assumes the responsibility for providing you a safe product and safety guidelines during its use. “Safety” means protection to all individuals who install, operate, and service the transmitter as well as protection of the transmitter itself. To promote safety, we use standard hazard alert labeling on the product and in this manual. Follow the associated guidelines to avoid potential hazard.

1.5.1 Dangers

DANGER represents the most severe hazard alert. Extreme bodily harm or death will occur if DANGER guidelines are not followed.

1.5.2 Warnings

WARNING represents hazards which could result in severe injury or death.

1.5.3 Cautions

CAUTION indicates potential personal injury, or equipment or property damage if the associated guidelines are not followed. Particular cautions in this text also indicate unauthorized radio-frequency operation.

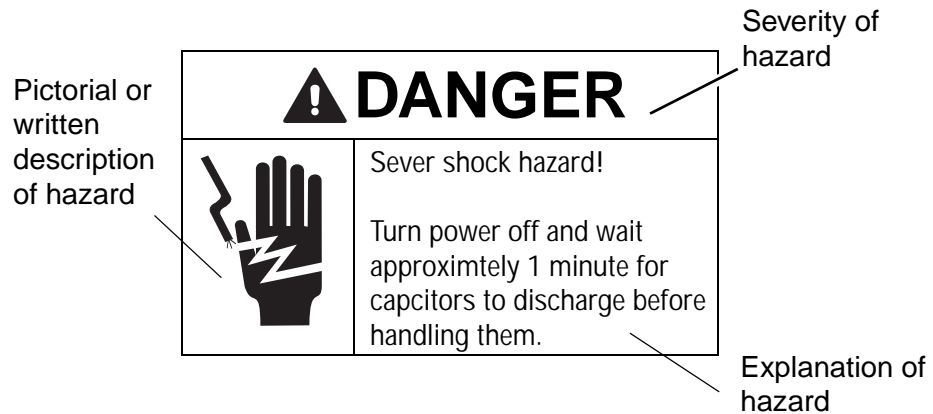
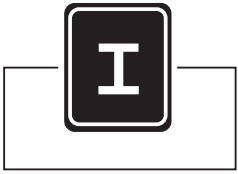
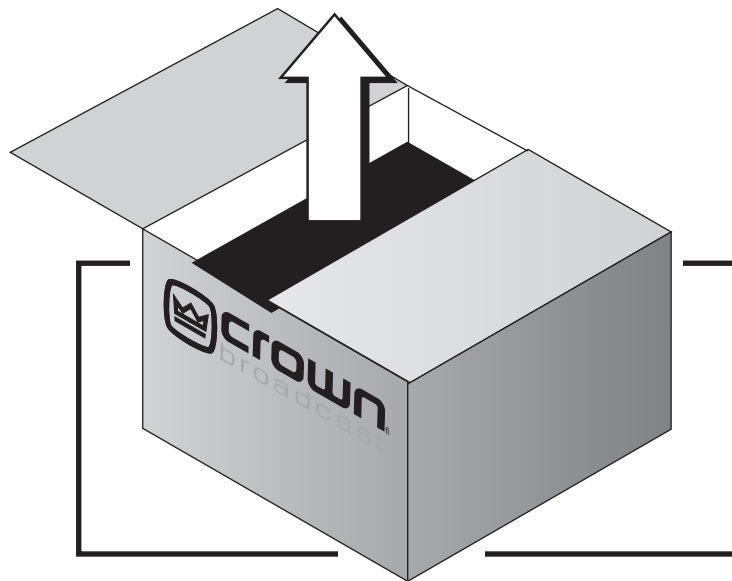

Illustration 1-4 Hazard Warning



Rev A



Section 2—Installation

This section provides important guidelines for installing your transmitter. Review this information carefully for proper installation.

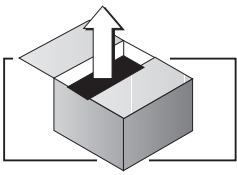

CAUTION

Possible equipment damage!

Before operating the transmitter for the first time, check for the proper AC line voltage setting and frequency described in Section 2.2, Power Connections and Section 2.3, Frequency (Channel) Selection.

2.1 Operating Location

You can install the FM transmitter in a standard component rack or on a suitable surface such as a bench or desk. In any case, the area should be as clean and well-ventilated as possible. Always allow for at least 2 cm of clearance under the unit for ventilation. If you set the transmitter on a flat surface, install spacers on the bottom cover plate. If you install the transmitter in a rack, provide adequate clearance above and below. Do not locate the transmitter directly above a hot piece of equipment.

2.2 Power Connections

The FM250G operates on 120 or 240 volts AC (50 or 60 Hz; single phase). As shipped (factory default settings), the FM250G operates on 240 volts at 60 Hz.

If you are operating the transmitter at 240 volts you do not need to make any changes. To operate the FM250G at 120 volts, make the following changes.

To change the voltage setting, perform the following steps:

1. Disconnect the power cord if it is attached.
2. Open the cover of the power connector assembly using a small, flat blade screwdriver. See Illustration 2-1, Opening the Power Connector Cover.
3. Insert the screwdriver into the top slot of the voltage selection assembly (red) and pry out the assembly from the power connector.
4. If you are setting the input voltage for 120 volts, replace the installed fuses with 10 amp fuses (included in your package). See Illustration 2-2, Removing the Voltage Selection (red) Assembly.
5. Replace the red fuse assembly so that the "120V" setting appears right side up in the window. Close the assembly window.

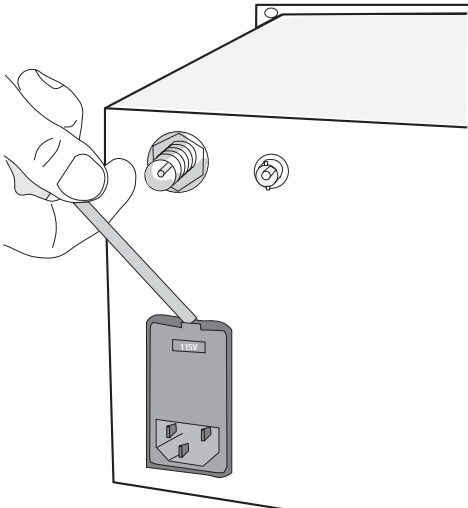

Illustration 2-1 Opening the Power Connector Cover

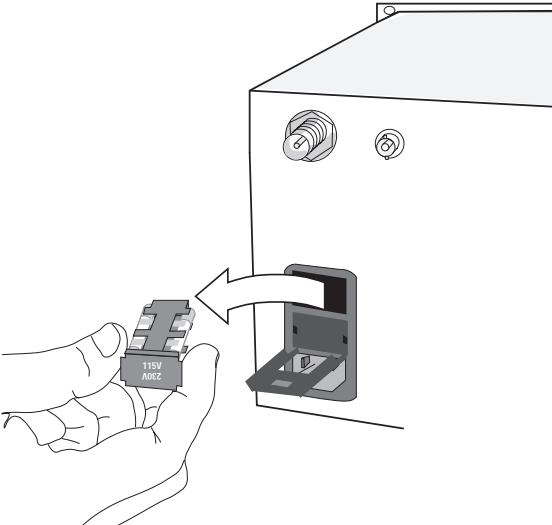
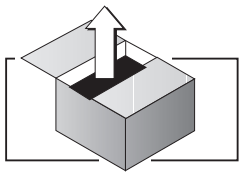

Illustration 2-2 Removing the Voltage Selection (red) Assembly

6. Connect the AC power cord.

Input Power	Fuze Size
120 VAC	10 ampere
240 VAC	4 ampere

Table 2-1 Fuse Size



2.3 Frequency (Channel) Selection

You may select an operating frequency of 87 to 108 MHz in the FM broadcast band. Pins 2 and 3 of JP1 on the RF Exciter board are jumpered for these frequencies.

To adjust the operating frequency, follow these steps:

1. Remove the top cover by removing 18 screws.
2. Locate the RF Exciter board and identify the frequency selector switches which will be used to change the setting. See Illustration 2-3, Top Cover Removed, and Illustration 2-4, RF Exciter Board (Frequency Selector Switches)..

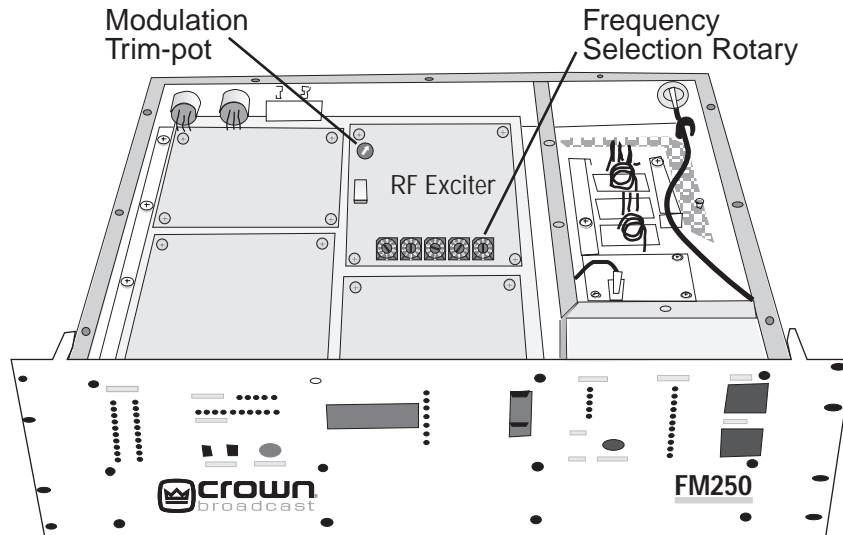

Illustration 2-3 Top Cover Removed

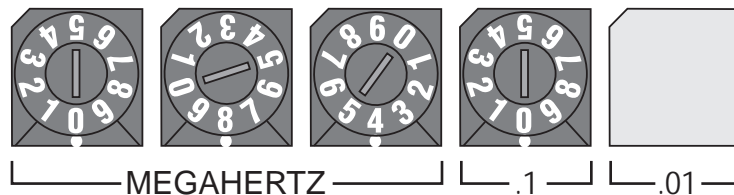

Illustration 2-4 RF Exciter Board (Frequency Selector Switches)

3. Use small flat blade screwdriver or another suitable device to rotate the switches to the desired setting. (The selected number will appear directly above the white indicator dot on each switch.) See examples of selected frequencies in the illustration below.

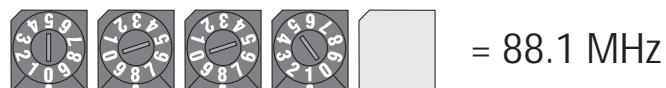

Illustration 2-5 Example Frequency Selections

2.3.1 Modulation Compensator

The Modulation trim-potentiometer, (see Section 2-6, Modulation Compensator Settings), compensates for slight variations in deviation sensitivity with frequency. Set the trim-pot dial according to the following graph:

Modulation Compensation Pot Setting

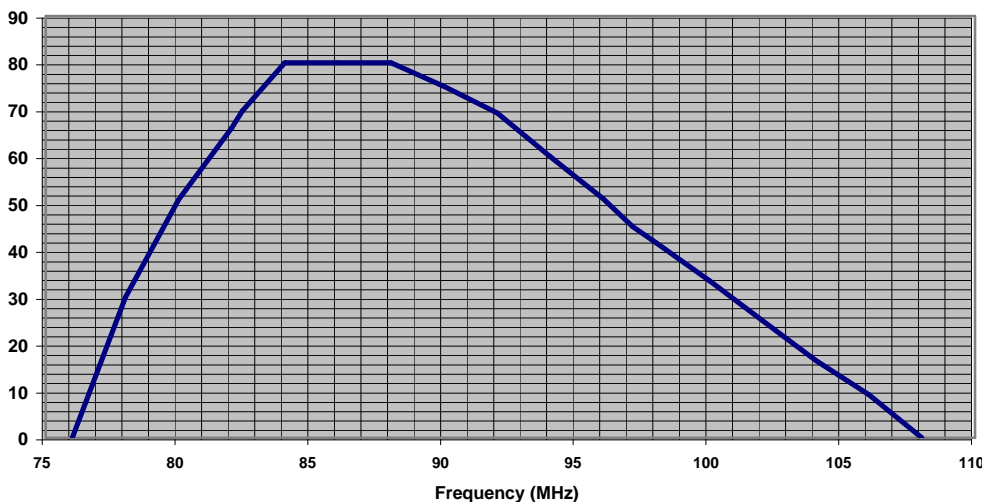

Illustration 2-6 Modulation Compensator Settings

These compensator settings are approximate. Each mark on the potentiometer represents about 1.8% modulation compensation. For more exact settings, see Section 5.2.2, Composite Output.

Replace the top cover before operating the transmitter.

2.3.2 RF Tuning Adjustments

All the RF stages are broadband to cover the 88 to 108 MHz broadcast band. The RF amplifier stages require no tuning.

Note: If you requested it, the FSK chip on the RF Exciter Board has been pre-programmed for your operating frequency. This chip is replaceable. Should you need to change the location of your translator, contact Crown Broadcast for a replacement chip with your new FSK ID. To disable auto ID, remove the jumper from the auto ID location on header HD2 on the RF Exciter Board.

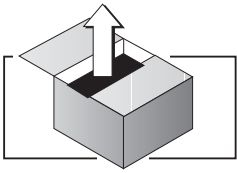

2.4 Receiver Frequency Selection

If you have a transmitter equipped with the receiver option, you will need to set the receiving or incoming frequency.

1. With the top cover removed, locate the receiver module and the two switches (labeled SW1 and SW2).

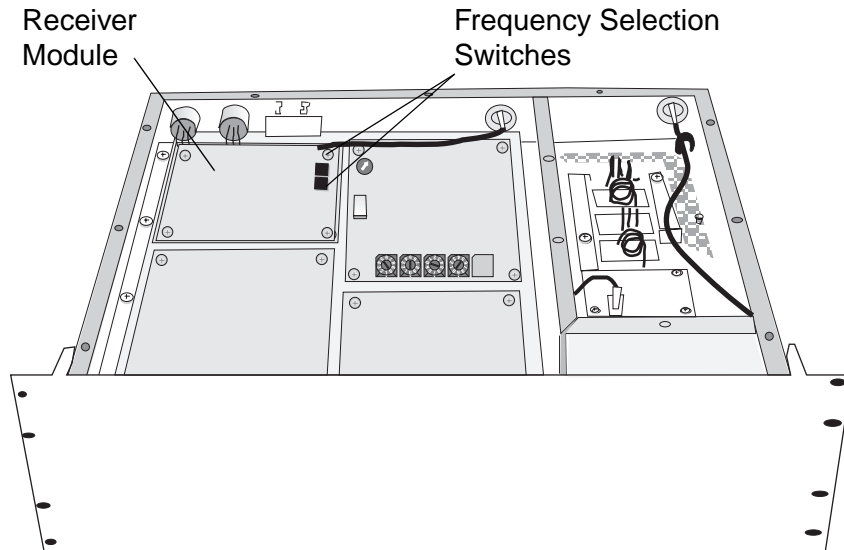

Illustration 2-7 Receiver Module Switches

2. Use Table 2-2, Receiver Frequency Selection, to set the switches for the desired incoming frequency.

After setting the frequency, return to Section 2.3.1, Modulation Compensator, to set the modulation compensator.

Note: If you requested it, the FSK chip on the RF Exciter Board has been pre-programmed for your operating frequency. This chip is replaceable. Should you need to change the location of your translator, contact Crown Broadcast for a replacement chip with your new FSK ID.

Replace the top cover before operating the transmitter.

Frequency	SW1	SW2	Frequency	SW1	SW2	Frequency	SW1	SW2	Frequency	SW1	SW2
87.9	0	0	92.9	1	9	97.9	3	2	102.9	4	B
88.0	8	0	93.0	9	9	98.0	B	2	103.0	C	B
88.1	0	1	93.1	1	A	98.1	3	3	103.1	4	C
88.2	8	1	93.2	9	A	98.2	B	3	103.2	C	C
88.3	0	2	93.3	1	B	98.3	3	4	103.3	4	D
88.4	8	2	93.4	9	B	98.4	B	4	103.4	C	D
88.5	0	3	93.5	1	C	98.5	3	5	103.5	4	E
88.6	8	3	93.6	9	C	98.6	B	5	103.6	C	E
88.7	0	4	93.7	1	D	98.7	3	6	103.7	4	F
88.8	8	4	93.8	9	D	98.8	B	6	103.8	C	F
88.9	0	5	93.9	1	E	98.9	3	7	103.9	5	0
89.0	8	5	94.0	9	E	99.0	B	7	104.0	D	0
89.1	0	6	94.1	1	F	99.1	3	8	104.1	5	1
89.2	8	6	94.2	9	F	99.2	B	8	104.2	D	1
89.3	0	7	94.3	2	0	99.3	3	9	104.3	5	2
89.4	8	7	94.4	A	0	99.4	B	9	104.4	D	2
89.5	0	8	94.5	2	1	99.5	3	A	104.5	5	3
89.6	8	8	94.6	A	1	99.6	B	A	104.6	D	3
89.7	0	9	94.7	2	2	99.7	3	B	104.7	5	4
89.8	8	9	94.8	A	2	99.8	B	B	104.8	D	4
89.9	0	A	94.9	2	3	99.9	3	C	104.9	5	5
90.0	8	A	95.0	A	3	100.0	B	C	105.0	D	5
90.1	0	B	95.1	2	4	100.1	3	D	105.1	5	6
90.2	8	B	95.2	A	4	100.2	B	D	105.2	D	6
90.3	0	C	95.3	2	5	100.3	3	E	105.3	5	7
90.4	8	C	95.4	A	5	100.4	B	E	105.4	D	7
90.5	0	D	95.5	2	6	100.5	3	F	105.5	5	8
90.6	8	D	95.6	A	6	100.6	B	F	105.6	D	8
90.7	0	E	95.7	2	7	100.7	4	0	105.7	5	9
90.8	8	E	95.8	A	7	100.8	C	0	105.8	D	9
90.9	0	F	95.9	2	8	100.9	4	1	105.9	5	A
91.0	8	F	96.0	A	8	101.0	C	1	106.0	D	A
91.1	1	0	96.1	2	9	101.1	4	2	106.1	5	B
91.2	9	0	96.2	A	9	101.2	C	2	106.2	D	B
91.3	1	1	96.3	2	A	101.3	4	3	106.3	5	C
91.4	9	1	96.4	A	A	101.4	C	3	106.4	D	C
91.5	1	2	96.5	2	B	101.5	4	4	106.5	5	D
91.6	9	2	96.6	A	B	101.6	C	4	106.6	D	D
91.7	1	3	96.7	2	C	101.7	4	5	106.7	5	E
91.8	9	3	96.8	A	C	101.8	C	5	106.8	D	E
91.9	1	4	96.9	2	D	101.9	4	6	106.9	5	F
92.0	9	4	97.0	A	D	102.0	C	6	107.0	D	F
92.1	1	5	97.1	2	E	102.1	4	7	107.1	6	0
92.2	9	5	97.2	A	E	102.2	C	7	107.2	E	0
92.3	1	6	97.3	2	F	102.3	4	8	107.3	6	1
92.4	9	6	97.4	A	F	102.4	C	8	107.4	E	1
92.5	1	7	97.5	3	0	102.5	4	9	107.5	6	2
92.6	9	7	97.6	B	0	102.6	C	9	107.6	E	2
92.7	1	8	97.7	3	1	102.7	4	A	107.7	6	3
92.8	9	8	97.8	B	1	102.8	C	A	107.8	E	3
									107.9	6	4
									108.0	E	4

Table 2-2 Receiver Frequency Selection

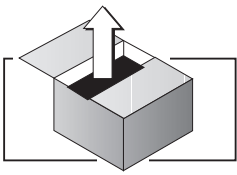

2.5 RF Connections

Connect the RF load, antenna or the input of an external power amplifier, to the type-N, RF output connector on the rear panel. VSWR should be 1.5:1 or better.

! Warning	
	<p>Severe shock hazard!</p> <p>Do not touch the inner portion of the RF output connector when transmitter power is on.</p>

The RF monitor is intended primarily for a modulation monitor connection. Information gained through this connection can supplement that which is available on the transmitter front panel displays.

If your transmitter is equipped with the receiver option, connect the incoming RF to the RF IN connector.

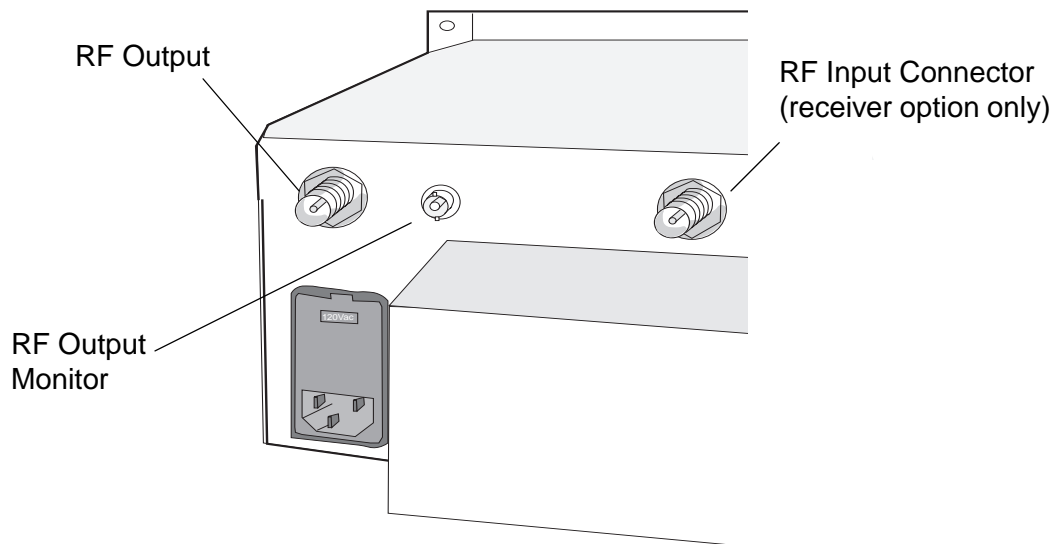

Illustration 2-8 RF Connection

2.6 Audio Input Connections

Attach audio inputs to the Left and Right XLR connectors on the rear panel. (The Left channel audio is used on Mono.) Pin 1 of the XLR connector goes to chassis ground. Pins 2 and 3 represent a balanced differential input with an impedance of about 50 k Ω . They may be connected to balanced or unbalanced left and right program sources.

The audio input cables should be shielded pairs, whether the source is balanced or unbalanced. For an unbalanced program source, one line (preferably the one connecting to pin 3) should be grounded to the shield at the source. Audio will then connect to the line going to pin 2.

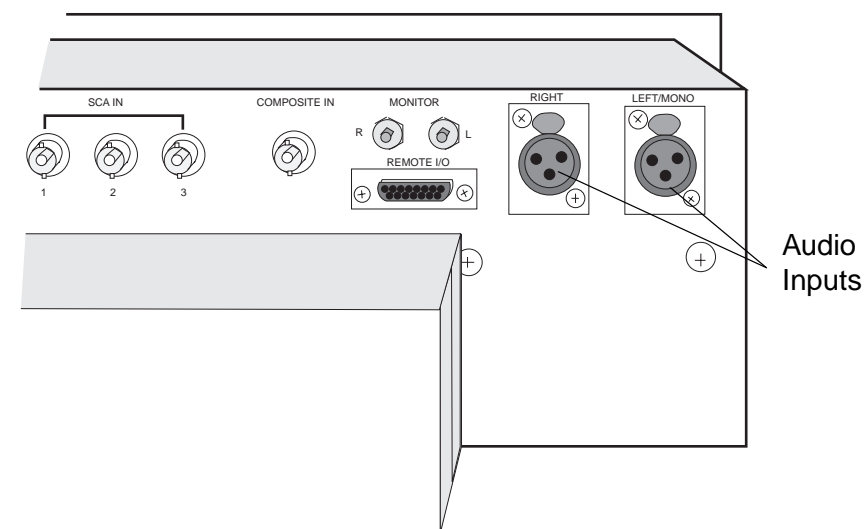
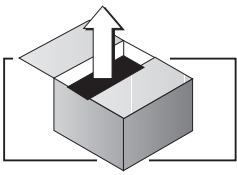

Illustration 2-9 XLR Audio Input Connections

By bringing the audio return line back to the program source, the balanced differential input of the transmitter is used to best advantage to minimize noise. This practice is especially helpful if the program lines are fairly long, but is a good practice for any distance.

If the program source requires a 600 Ω termination, install resistors on the 8-pin DIP socket on the motherboard (socket A501 located between the XLR connectors). See Section 6.2, Board Layouts and Schematics.



2.7 SCA Input Connections

You can connect external SCA generators to the SCA In connectors (BNC-type) on the rear panel. The inputs are intended for the 60 kHz to 99 kHz range, but a lower frequency may be used if the transmitter is operated in Mono mode. (The 23 to 53 kHz band is used for stereo transmission.) For 7.5 kHz deviation (10% modulation), input of approximately 3.5-volts (peak-to-peak) is required

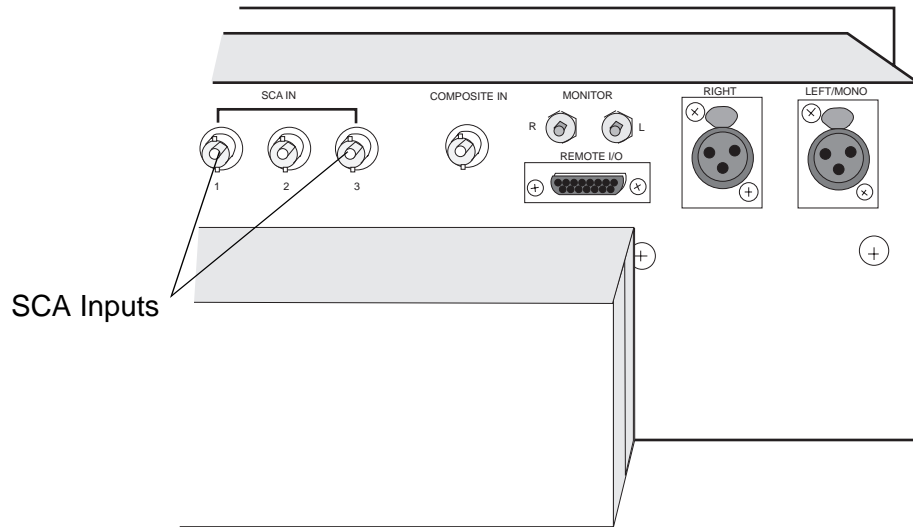

Illustration 2-10 SCA Input Connections

2.8 Composite Input Connection

You may feed composite stereo (or mono audio) directly to the RF exciter, bypassing the internal audio processor and stereo generator. To use the Crown transmitter as an RF Exciter only (“E” version or when using the “T” version with composite input), it is necessary to use the Composite Input section of the transmitter. This will feed composite stereo (or mono audio) directly to the RF exciter. In the “T” version, this will bypass the internal audio processor and stereo generator. See Section 2.11 on the next page for caution in using the bypass option.

Input sensitivity is approximately 3.5-volt P-P for 75 kHz deviation.

1. Enable the Composite Input by grounding pin 9 of the Remote I/O connector (see Section 2-13, Remote I/O Connector).
2. Connect the composite signal to the Composite In BNC connector.

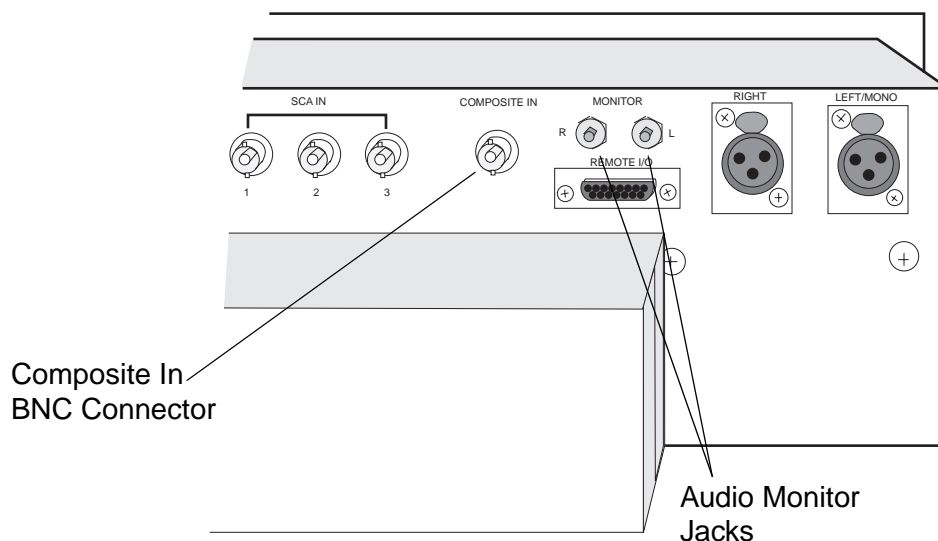

Illustration 2-11 Composite In and Audio Monitor Connections

2.9 Audio Monitor Connections

Processed, de-emphasized samples of the left and right audio inputs to the stereo generator are available at the Monitor jacks on the rear panel. The signals are suitable for feeding a studio monitor and for doing audio testing. De-emphasis is normally set for 75 $\mu\text{sec.}$; set to 50 $\mu\text{sec.}$ by moving jumpers, JP203 and JP204, on the Stereo Generator board. See Section 5.8.2, De-emphasis Input Network, for further information.)

2.10 Pre-emphasis Selection

Select the pre-emphasis curve (75 $\mu\text{sec.}$, 50 $\mu\text{sec.}$, 25 $\mu\text{sec.}$, or Flat) by jumpering the appropriate pins of header JP1 on the audio processor board. If you change the pre-emphasis, change the de-emphasis jumpers JP203 and JP204 on the Stereo Generator board to match. (See Section 2.8, Composite Input Connection for additional information.)

2.11 Processor Bypass Option

You may bypass the audio processor in order to feed the left and right (pre-emphasized) audio directly to the stereo generator. The Normal-Bypass slide switch is near the left-rear corner of the motherboard. If the audio source is already processed and you do not desire further processing, use the Normal mode, but turn the Processing control (on the front panel) to "0." (See also Section 3.4, Processing Control.)

⚠ CAUTION

In the BYPASS position, the pre-emphasis circuits and the filters that protect the pilot and stereo subcarrier are bypassed. As a result, the occupied bandwidth specifications of the transmitter could be compromised. The 15-Hz high-pass filters are also bypassed which may mean that modulation with frequencies below 10 Hz could cause the frequency synthesizer to unlock.

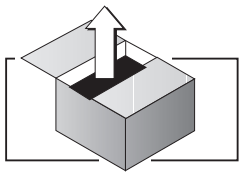

2.12 Program Input Fault Time-out

You can enable an automatic turn-off of the carrier in the event of program failure. To enable this option, select a setting from Table 2-3, Fault Time-out Values. The time between program failure and carrier turn-off is set by a jumper (JP701) on the voltage regulator board. (See Illustration 6-4 , Chassis Bottom View)for board location).

Delay	Pins to Jumper
30 seconds	1-2 (pins closest to edge)
2 minutes	3-4
4 minutes	5-6
8 minutes	7-8

Table 2-3 Fault Time-out Values

2.13 Remote I/O Connector

Remote control and remote metering of the transmitter is made possible through a 15-pin, D-sub connector on the rear panel. (No connections are required for normal operation).

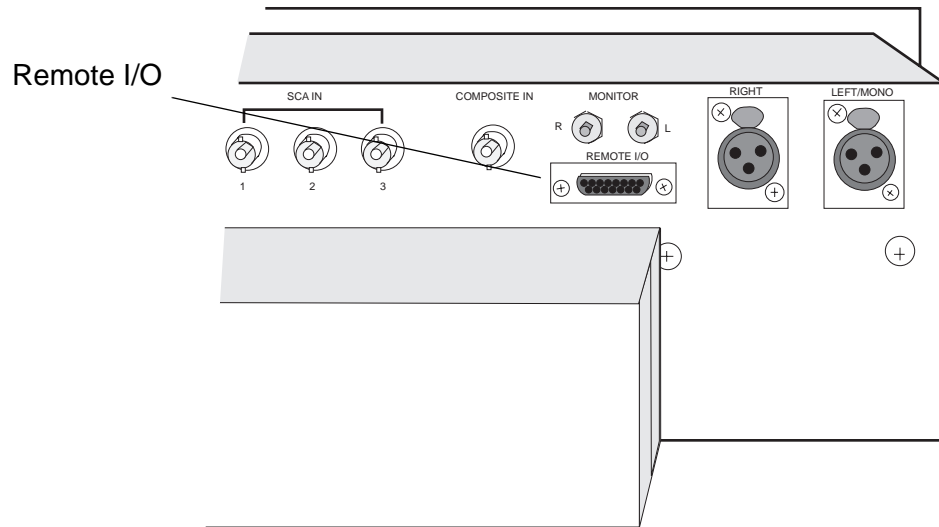

Illustration 2-12 Remote I/O Connector

Table 2-4, Remote I/O Connector, summarizes the Remote I/O pin connections.

Pin Number	Function
1	Ground
2	(no connection)
3	Composite Out (sample of stereo generator output)
4	FSK In (Normally high; pull low to shift carrier frequency approximately 7.5 kHz. Connect to open collector or relay contacts of user-supplied FSK keyer.)
5	/Auto Carrier Off (Pull low to enable automatic turnoff of carrier with program failure.)
6	Meter Battery (unregulated DC voltage; 5 volts = 50 VDC)
7	Meter RF Watts (1 volt = 100 watts)
8	Meter PA Volts (5 volts = 50 VDC)
9	/Ext. Enable (Pull low to disable internal stereo generator and enable External Composite Input.)
10	a) 38 kHz Out (From stereo generator for power supply synchronization.) b) For transmitters equipped with tuner option, this pin becomes the right audio output for an 8-ohm monitor speaker. 38kHz Out is disabled.
11	ALC
12	/Carrier Off (pull low to turn carrier off.)
13	Fault Summary (line goes high if any fault light is activated.)
14	Meter PA Temperature (5 volts = 100 degrees C.)
15	Meter PA Current (1 volt = 10 amperes DC.)

Table 2-4 Remote I/O Connector

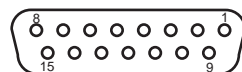
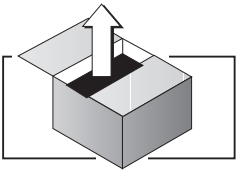
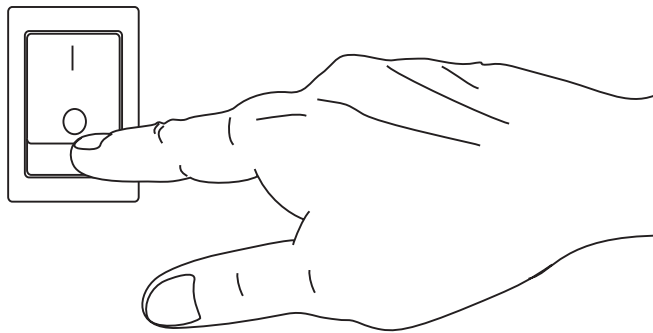

Illustration 2-13 Remote I/O Connector



Rev A



Section 3—Operation

This section provides general operating parameters of your transmitter and a detailed description of its front panel display.

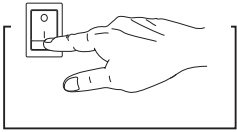

3.1 FM250G Initial Power-up Procedures

These steps summarize the operating procedures you should use for the initial operation of the transmitter. More detailed information follows.

⚠ Caution

Possible equipment damage!

Before operating the transmitter for the first time, check for the proper AC line voltage setting and frequency selection as described in Section 2.2 and 2.3.

1. Turn on the main power switch.

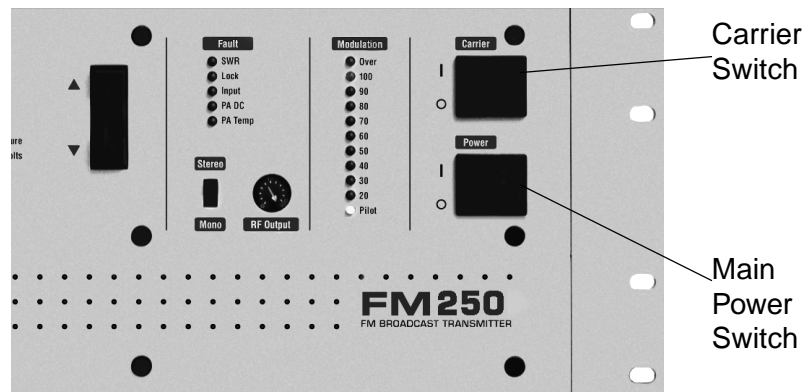

Illustration 3-1 Front Panel Power Switches

2. Verify the following:
 - a. The bottom cooling fan runs continuously.
 - b. The Lock Fault indicator flashes for approximately 5 seconds, then goes off.
3. Set the Input Gain switches for mid-scale wideband gain reduction on an average program level (see Section 3.3, Input Gain Switches).
4. Set the Processing control (see Section 3.4, Processing Control; normal setting is "50").
5. Set the Stereo-Mono switch to Stereo (see Section 3.5, Stereo-Mono Switch).
6. Turn on the Carrier switch.
7. Check the following parameters on the front panel multimeter:
 - a. RF Power should be 250–275 watts.
 - b. SWR should be less than 1.1. (A reading greater than 1.25 indicates an antenna mismatch.)
 - c. ALC should be between 3.50 and 5.50 volts.
 - d. PA DC Volts should be 35 to 45 volts. (Varies with antenna match, power, and frequency.)
 - e. PA DC Amperes should be 10-12 amps for the FM250G. (Varies with

- antenna match, power, and frequency.)
- f. PA Temperature should initially read 20–35 degrees C (room temperature). After one hour the reading should be 45-55 degrees C. Maximum operating temperature is 55 degrees C.
 - g. Supply DC volts should display a typical reading of 55-56 volts with the carrier on or off.
 - h. Voltmeter should be reading 0.0.

The remainder of this section describes the functions of the front panel indicators and switches.

3.1.1 Power Switch

The main on/off power switch controls the 120/240 VAC.

3.1.2 Carrier Switch

This switch controls power to the RF amplifiers and supplies a logic high to the voltage regulator board, which enables the supply for the RF driver. In addition, the Carrier Switch controls the operating voltage needed by the switching power regulator.

A “Lock Fault” or a low pin 12 (/Carrier Off) on the Remote I/O connector will hold the carrier off. (See Illustration 2–13, Remote I/O Connector)

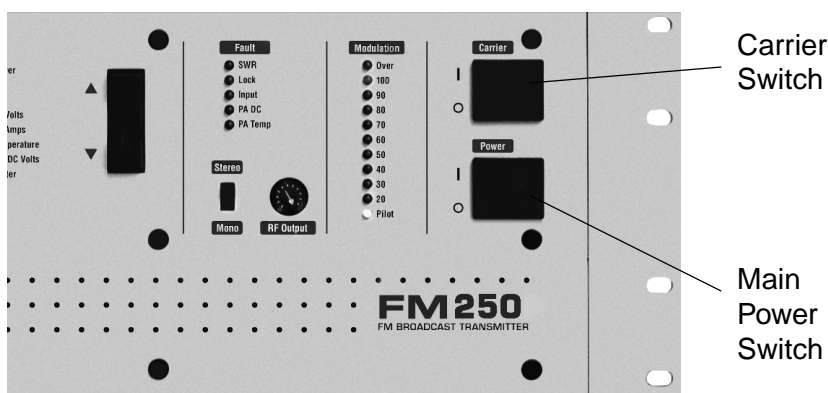
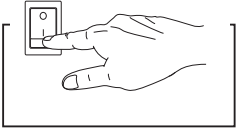

Illustration 3-2 Front Panel Power Switches



3.2 *Front Panel Bar-Dot Displays*

Bar-dot LEDs show audio input levels, wideband and highband audio gain control, and modulation percentage. Resolution for the gain control and modulation displays is increased over a conventional bar-graph display using dither enhancement which modulates the brightness of the LED to give the effect of a fade from dot to dot. (Section 4.7, Display Circuit Board)

3.2.1 **Audio Processor Input**

Two vertical, moving-dot displays for the left and right channels indicate the relative audio levels, in 3 dB steps, at the input of the audio processor. Under normal operating conditions, the left and right Audio Processor indicators will be active, indicating the relative audio input level after the Input Gain switches. During program pauses, the red Low LED will light.

The translator configuration shows relative audio levels from the included receiver.

3.2.2 **Highband and Wideband Display**

During audio processing, the moving-dot displays indicate the amount of gain control for broadband (Wide) and pre-emphasized (High) audio.

As long as program material causes activity of the Wideband green indicators, determined by the program source level and Input Gain switches, the transmitter will be fully modulated. (See Section 3.3, Input Gain Switches)

The Wideband indicator shows short-term “syllabic-rate” expansion and gain reduction around a long-term (several seconds) average gain set. In the translator configuration, the Wideband indicator also shows relative RF signal strength.

Program material and the setting of the Processing control determine the magnitude of the short-term expansion and compression (the rapid left and right movement of the green light).

High-frequency program content affects the activity of the Highband indicator. With 75- μ sec pre-emphasis, Highband processing begins at about 2 kHz and increases as the audio frequency increases. Some programs, especially speech, may show no activity while some music programs may show a great deal of activity.

3.2.3 **Modulation Display**

A 10-segment, vertical peak-and-hold, bar graph displays the peak modulation percentage. A reading of “100” coincides with 75 kHz deviation. The display holds briefly (about 0.1 seconds) after the peak. The “Pilot” indicator illuminates when the transmitter is in the stereo mode.

To verify the actual (or more precise) modulation percentage, connect a certified modulation monitor to the RF monitor jack on the rear panel.

3.3 *Input Gain Switches*

The “+6 dB” and “+12 dB” slide switches set audio input sensitivity according to the following table.

Nominal Input Sensitivity	Switches	
	+6 dB	+12 dB
+10 dBm	Down	Down
+4 dBm	Up	Down
-2 dBm	Down	Up
-8 dBm	Up	Up

Illustration 3-3 Input Gain Switches

Find, experimentally, the combination of Input Gain switch settings that will bring the Wideband gain-reduction indicator to mid scale for “normal” level program material. The audio processor will accommodate a fairly wide range of input levels with no degradation of audio quality.

3.4 *Processing Control*

Two factors contribute to the setting of the Processing control: program material and personal taste. For most program material, a setting in the range of 40 to 70 provides good program density. For the classical music purist, who might prefer preservation of music dynamics over density, 10 to 40 is a good range. The audio will be heavily processed in the 70 to 100 range.

If the program source is already well processed, as might be the case with a satellite feed, set the Processing to “0” or “10”.

3.5 *Stereo-Mono Switch*

The Stereo-Mono slide switch selects the transmission mode. In Mono, feed audio *only to the left channel*. Although right-channel audio will not be heard as audio modulation, it will affect the audio processing.

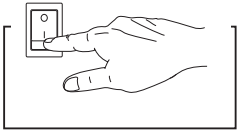

3.6 RF Output Control

Set this control for the desired output power level. Preferably, set the power with an external RF wattmeter connected in the coaxial line to the antenna. You may also use the RF power reading on the digital multimeter.

The control sets the RF output voltage. Actual RF output power varies as the approximate square of the relative setting of the control. For example, a setting of “50” is approximately 1/4 full power. Operation below 10 watts is not recommended.

3.7 Digital Multimeter

The four-digit numeric display in the center of the front panel provides information on transmitter operation. Use the “Up” and “down” push-buttons to select one of the following parameters. A green LED indicates the one selected.

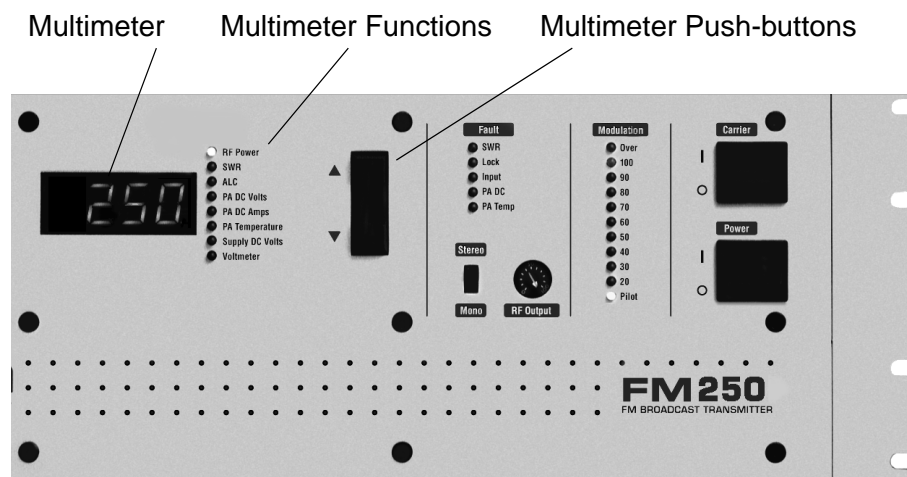

Illustration 3-4 Digital Multimeter

RF Power—Actually reads RF voltage squared, so the accuracy can be affected by VSWR (RF voltage-to-current ratio). See Section 5.4, Metering Board Adjustments, for calibration. Requires calibration with the RF reflectometer being used.

SWR—Direct reading of the antenna standing-wave ratio (the ratio of the desired load impedance, 50 ohms, to actual load).

ALC—DC gain control bias used to regulate PA supply voltage. With the PA power supply at full output voltage, ALC will read about 6.0 volts. When the RF output is being regulated by the RF power control circuit, this voltage will be reduced, typically reading 4 to 5.5 volts. The ALC voltage will be reduced during PA DC overcurrent, SWR, or LOCK fault conditions.

PA DC Volts—Supply voltage of the RF power amplifier.

PA DC Amps—Transistor drain current for the RF power amplifier.

PA DC Temperature—Temperature of the RF power amplifier heatsink in degrees C.

Supply DC Volts—Unregulated DC voltage at the input of the voltage regulators.

Voltmeter—Reads the voltage at a test point located on the front edge of the motherboard. A test lead connected to this point can be used for making voltage measurements in the transmitter. The test point is intended as a servicing aid; an alternative to an external test meter. Remember that the accuracy is only as good as the reference voltage used by the metering circuit. Servicing a fault affected by the reference affects the Voltmeter reading. The metering scale is 0 to 199.9 volts.

In the translator configuration, you can read a relative indication of RF signal strength numerically in the Voltmeter setting.

3.8 *Fault Indicators*

Faults are indicated by a blinking red light as follows:

SWR—Load VSWR exceeds 1.5:1. ALC voltage is reduced to limit the reflected RF power.

Lock—Frequency synthesizer phase-lock loop is unlocked. This indicator normally blinks for about five seconds at power turn-on. Whenever this light is blinking, supply voltages will be inhibited for the RF driver stage as well as for the RF power amplifier.

Input—The automatic carrier-off circuit is enabled (see Section 2.11, Processor Bypass Option and Section 2.12, Program Input Fault Time-out) and the absence of a program input signal has exceeded the preset time.

Note: The circuit treats white or pink noise as an absence of program audio. Identical left and right but out of phase signals will also cause a fault.

PA DC—Power supply current for the RF power output amplifier is at the preset limit. ALC voltage has been reduced, reducing the PA supply voltage to hold supply current to the preset limit.

PA Temp—PA heatsink temperature has reached 70° C (158° F).

At about 72° C (162° F), ALC voltage begins to decrease, reducing the PA supply voltage to prevent a further increase in temperature. By 75° C (167° F), the PA will be fully cut off. The heatsink fan is proportionally controlled to hold the heatsink at 35° C (95° F). Above this temperature, the fan runs at full speed.

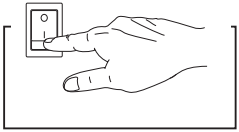

Rev A

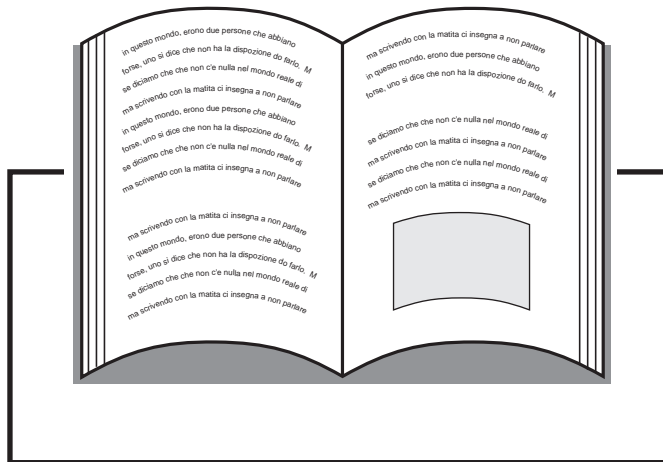

Section 4—Principles of Operation

This section discusses the circuit principles upon which the transmitter functions. This information is not needed for day-to-day operation of the transmitter but may be useful for advanced users and service personnel.

4.1 Part Numbering

As this section refers to individual components, you should be familiar with the part numbering scheme used. Although parts on the various circuit boards and circuit board drawings may be marked with identical reference numbers, each component in the transmitter has a unique part reference number.

The circuit boards and component placement drawings use designators such as “R1”, “R2”, and “C1.” These numbers represent only a portion of the full part numbers (as shown on the schematic). To find the full number, refer to the chart below. R401, for instance, is marked “R1” on the Metering board and on its component placement drawing.

Circuit Name	Part numbers
Audio Processor	0-199
Stereo Generator	200-299
RF Exciter/Synthesizer	300-399
Metering/Protection	400-499
Motherboard	500-599
Display	600-699
Voltage Regulator	700-799
Power Regulator	800-899
RF Predriver	900-999
Chassis Wiring	1000-1099
RF Power Amplifier	1100-1199
RF Low-Pass Filter	1200-1299

Table 4-1 Component Part Numbering

4.2 Audio Processor Circuit Board

The audio processor board provides the audio control functions of a compressor, limiter, and expander. Illustration 6-5 and accompanying schematic may be useful to you during this discussion.

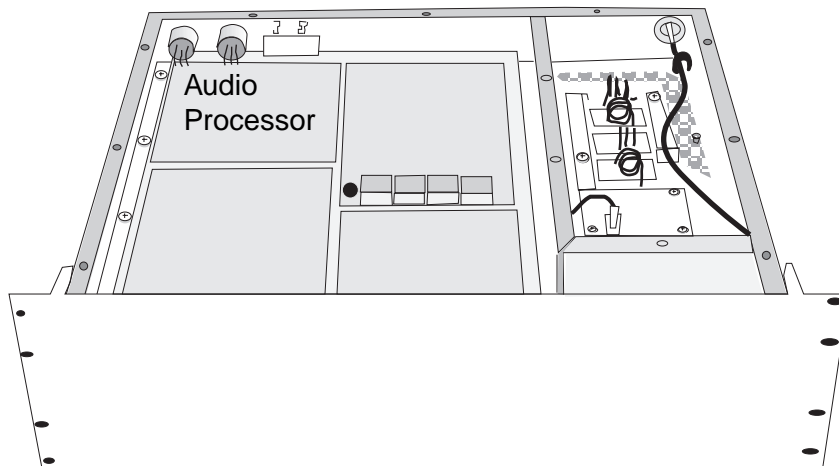

Illustration 4-1 Audio Processor Board

This board also contains the pre-emphasis networks. Reference numbers are for the left channel. Where there is a right-channel counterpart, references are in

parenthesis. One processor circuit, the eighth-order elliptical filter, is located on the stereo generator board.

Audio input from the XLR connector on the rear panel of the transmitter goes to differential-input amplifier, U1A (U2A).

Binary data on the +6 dB and +12 dB control lines sets the gain of inverting amplifier U1B (U2B). Analog switch, U3, selects one of four feedback points in 6-dB steps.

The output of U1B (U2B) goes to an eighth-order, elliptical, switched-capacitor, low-pass, 15.2-kHz filter. The filter finds its home on the stereo generator board to take advantage of the ground plane and proximity to the 1.52 MHz clock.

The circuit associated with U4B (U4A), along with R22/C8 (R58/C20), form third-order, low-pass filtering, attenuating audio products below 30 Hz.

The output level of analog multiplier U5 (U6) is the product of the audio signal at pin 13 and the DC voltage difference between pins 7 and 9. At full gain (no gain reduction) this difference will be 10 volts DC.

When either the positive or negative peaks of the output of U5 (U6) exceeds the gain-reduction threshold, U13A generates DC bias, producing broadband gain reduction. Q5 is a precision-matched transistor pair. Q5 and U13B form a log converter, so that a given voltage change produces a given change in gain control dB of U5 (U6). The log conversion ensures uniform level-processing characteristics well beyond the 20-dB control range. The log conversion has an additional benefit; it allows a display of gain control on a linear scale with even distribution of dB.

Q1 (Q2) is a recover/expansion gate with a threshold about 18 dB below the normal program level. The amount of short-term expansion and gain reduction is controlled by R650, located on the front panel display board. (See section 3.5.)

Pre-emphasis, in microseconds, is the product of the capacitance of C10 (C22), multiplied by the gain of U8 (U9), times the value of R31 (R67). For a 75- μ second pre-emphasis, the gain of U8 (U9) will be about 1.11. Select the pre-emphasis curve (75 μ sec, 50 μ sec, 25 μ sec, or Flat) by jumpering the appropriate pins on header JP1. Use trim pot R29 (R65) to make fine adjustments to the pre-emphasis. (See section 5.1.)

For highband processing, the peak output of U10B is detected and gain-reduction bias is generated, as with the broadband processor. The highband processing, however, shifts the pre-emphasis curve rather than affecting overall gain.

Peak audio voltages are compared to a plus and minus 5-volt reference, U17 and U18. This same reference voltage is used by the stereo generator, metering, and display boards.

For an explanation of on-board adjustments see section 5.1.

4.3 Stereo Generator Circuit Board

The stereo generator board (see Illustration 4–3) generates a composite stereo signal from left and right-channel audio inputs. The component side of the board is mostly a ground plane. Once again, the eighth-order, 15.2-kHz, elliptical, low-pass filters (U201 and U202) are on this board, but belong to the audio processor.

Illustration 6–6 and accompanying schematic complement this discussion.

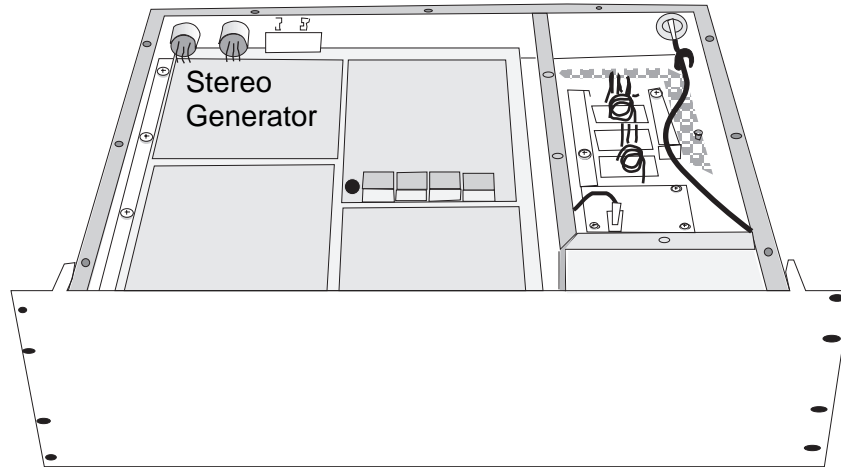

Illustration 4-2 Stereo Generator Board

U207A and Y201 comprise a 7.6-MHz crystal oscillator from which the 19 and 38-kHz subcarriers are digitally synthesized. U207F is a buffer. The 7.6 MHz is divided by 5 in U208A to provide 1.52 MHz at pin 6, used by filters U201 and U202. 3.8 MHz, 1.9 MHz, and 304 kHz are also derived from dividers in U208.

Exclusive-OR gates, U210A and U210B, provide a stepped approximation of a 38-kHz sine wave—a scheme described in the *CMOS Cookbook* by Don Lancaster (Howard W. Sams & Co., Inc., Indianapolis, IN, 1978).

With the resistor ratios used, the synthesized sine wave has very little harmonic energy below the 7th harmonic. U210C and D generate the 19-kHz pilot subcarrier. U211 is a dual, switched-capacitor filter, configured as second-order, low-pass filters, each with a Q of 5. The 38 and 19-kHz outputs of pins 1 and 20, respectively, are fairly pure sine waves. Harmonic distortion products are better than 66 dB down—THD of less than 0.05%.

U212 is a precision, four-quadrant, analog multiplier. The output of U212 is the product of 38 kHz applied to the “X” input and the difference of left and right audio (L-R signal) applied to the “Y” input. The resulting output is a double sideband, suppressed carrier—the L-R subcarrier.

The SCA subcarrier, the left, right, and left-minus-right subcarriers, and the 19-kHz pilot subcarrier are combined into the composite stereo signal by summing amplifier U206B.

Analog switch U205, at the input of U206B, provides switching of left and right audio for stereo and mono modes. In the mono mode, right channel audio is disabled, and the left channel audio is increased from 45% modulation to 100%.

MON L and MON R outputs go to the AF Monitor jacks on the rear panel. R208+R210 (R220+R222) and C207 (C211) comprise a 75- μ sec de-emphasis network. Processed, de-emphasized (75- μ sec) samples of the stereo generator input signals are used for a studio monitor and for audio testing. Option jumpers JP203 (JP204) allow you to select 50 μ sec.

VR201 and VR202 supply +6 volts and -6 volts, respectively. A 5-volt reference from the audio processor board supplies the subcarrier generators.

For an explanation of on-board adjustments see section 5.2.

4.4 RF Exciter Circuit Board

This board is also known as the Frequency Synthesizer board. The entire component side of the board is a ground plane. Frequency selector switches along the front edge of the board establish the operating frequency. The VCO (voltage-controlled oscillator) circuitry is inside a cast aluminum shield cover.

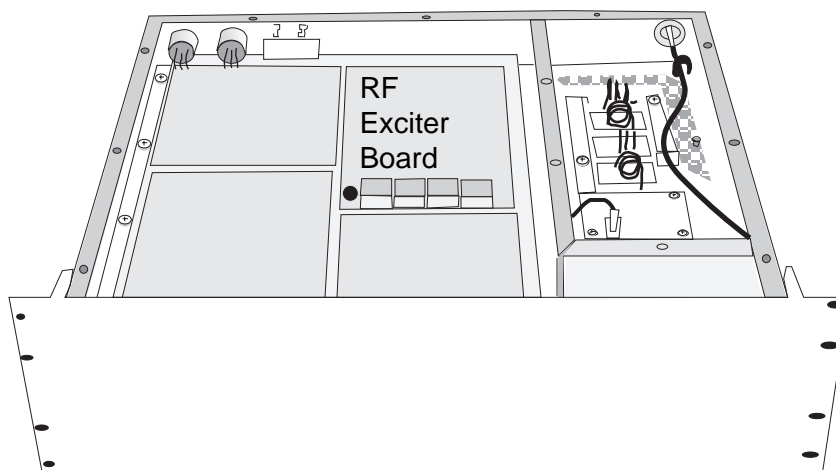

Illustration 4-3 RF Exciter Board

Illustration 6-7 and accompanying schematic can be used as reference in this discussion. The following theory may apply to previous versions of the exciter board, but it is typical of the operation of the current board.

VCO, Q301, operates at the synthesizer output frequency of 87 MHz to 108 MHz. The frequency is controlled by voltage-variable capacitors D307 and D308. Q304 and Q305 form an active filter to supply clean DC to the drain of Q301. Q305 also serves as a common-base RF amplifier for Q301. U308 and U309 are hybrid RF amplifiers to provide buffering and gain. (The circuit board has pads for Q302, ALC control of output. Source and drain pads are jumpered in the transmitter.)

A sample of the RF from the VCO goes to the input of U302. U302 is a dual modulus 10/11 divider that has been connected to divide by 10. The output of U302 is 8.7 to

10.8 MHz. This signal, available at TP202, may be used with a high frequency receiver for deviation and frequency measurements. (See sections 5.2 and 5.3.)

JP301 is a jumper option for bypassing U302 and is used only in transmitters which have been modified for operating in the Eastern Europe band (66–73 MHz).

U304 is a phase-locked-loop frequency synthesizer IC. The 10.24 MHz from the crystal oscillator is divided to 10 kHz. Internal programmable dividers (along with dual modulus divider U301) divide the 8.7 to 10.8 MHz RF to 10 kHz also. Differences between the two signals produce error signals at pins 7 and 8.

The U304 dividers are set with frequency selector switches. The binary output of the 0.1–MHz switch programs the “A” counter directly. BCD data from the selector switches is converted to binary data by EPROM U310 to set the “N” counter. There is also provision on the circuit board for using either DIP switches or jumpers to set the frequency. (See section 3.3.)

U305B is a differential amplifier and filter for the error signal. Audio that is out of phase with that appearing on the error voltage is introduced by U305A, allowing for greater loop bandwidth with less degradation of the low-frequency audio response. U306B is an integrator. Q303 is a VCO input voltage clamp.

D307 and D308 are hyper-abrupt varactor tuning diodes with a square-law capacitance vs. DC voltage curve, giving a straight-line frequency vs. voltage curve in a LC oscillator where the varactors are the dominant source of capacitance.

Lock and unlock status signals are available at the outputs of U303E and U303F, respectively. Modulation is introduced to the VCO through R351 and R326 to R329. About 4.1 millivolts across R329 produces 75 kHz deviation.

An FSK signal (used for automatic identification of FM repeaters) shifts the frequencies of the 10.24–MHz crystal reference and the VCO. With keying, diodes D310 and D311, are reverse biased, increasing the crystal reference frequency. At the same time, current through R358 increases the VCO frequency. See section 5.3.4.

4.5 Metering Circuit Board

The ALC and metering circuitry is on the metering board (see Illustration 4–5). This board processes information for the RF and DC metering, and produces ALC (RF level-control) bias. It also provides reference and input voltages for the digital panel

meter, voltages for remote metering, fan control, and drive for the front-panel fault indicators.

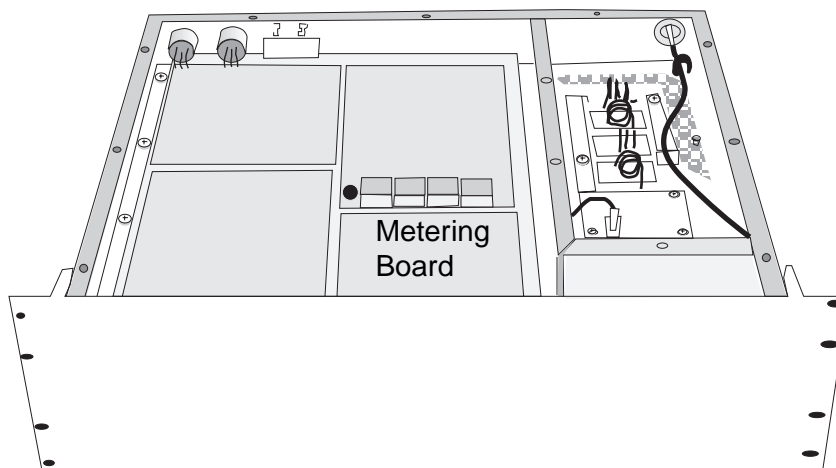

Illustration 4-4 Metering Board

Illustration 6–8 and accompanying schematic complement this discussion.

PA voltage and current come from a metering shunt on the power regulator board. The PAI input is a current proportional to PA current; R405 converts the current to voltage used for metering and control. A voltage divider from the PAV line is used for DC voltage metering.

U406A, U406B, and U407A, with their respective diodes, are diode linearity correction circuits. Their DC inputs come from diode detectors in the RF reflectometer in the RF low-pass filter compartment.

U407B, U407C, Q405, and Q406 are components of a DC squaring circuit. Since the DC output voltage of U407C is proportional to RF voltage squared, it is also proportional to RF power.

U404C, U404A, U403A, and U404D are level sensors for RF power, reflected RF power, PA temperature, and external PA current, respectively. When either of these parameters exceeds the limits, the output of U404B will be forced low, reducing the ALC (RF level control) voltage, which, in turn, reduces the PA supply voltage.

The DC voltage setpoint for U404A (reflected RF voltage) is one-fifth that of U404C (forward RF voltage). This ratio corresponds to an SWR of 1.5:1 $[(1+.2)/(1-.2)=1.5]$. The U405 inverters drive the front panel fault indicators.

To get a direct reading of SWR, the reference input of the digital panel meter is fed from a voltage proportional to the forward-minus-reflected RF voltage, while forward-plus-reflected is fed to the digital panel meter input. The panel meter provides the divide function.

U408 and U409 function as data selectors for the digital panel meter input and reference voltages. Binary select data for U408 and U409 comes from the display board.

The output voltage of U403D goes positive when the temperature exceeds about 35 degrees C (set by R426) providing proportional fan control.

When the Carrier switch is off or the RF power is less than about 5 watts, the SWR automatically switches to a calibrate-check mode. U406C provides a voltage that simulates forward power, while Q403 shunts any residual DC from the reflected-power source. The result is a simulation of a 1.0 to 1 SWR. (See Section 5.4, Metering Board Adjustments.)

4.6 *Motherboard*

The motherboard is the large board in the upper chassis interconnecting the audio processor, stereo generator, RF exciter, and metering boards. The motherboard provides the interconnections for these boards, eliminating the need for a wiring harness, and provides input/output filtering.

Motherboard components are passive with the exception of the fan driver transistor, power FET Q501.

With Normal-Bypass slide switch SW501, it is possible to bypass the audio processor, connecting the left and right audio inputs directly to the inputs of the stereo generator.

If the audio source is already processed, and further processing is not desired, use the Normal mode instead of Bypass and turn the Processing control on the front panel to “0.”

Caution

In the BYPASS position, the pre-emphasis circuits and the filter that protect the pilot and stereo subcarrier are bypassed. As a result, the occupied bandwidth specifications of the transmitter could be compromised. The 15-Hz high-pass filters are also bypassed which may mean that modulation with frequencies below 10 Hz could cause the frequency synthesizer to unlock.

If it is necessary to provide resistive terminations at the audio inputs (either line-to-line or line-to-ground), you may place resistors directly into the 8-pin DIP socket, A501, located between the XLR input connectors. See Illustration 6–9 and accompanying schematic for the socket pin-out.

4.7 *Display Circuit Board*

The front-panel LEDs, the numeric display, the slide switches, and the processing and RF level controls are mounted on the display circuit board. To access the component side of the board, remove the front panel by removing 12 screws. The board contains circuits for the digital panel meter, modulation peak detector, and LED display drivers, as well as indicators and switches mentioned above.

Illustration 6–10 and accompanying schematic complement this discussion.

Left and right audio from input stages of the audio processor board (just after the Input Gain attenuator) go to the L VU and R VU input on the display board. Peak rectifiers U601A and U601B drive the left and right Audio Input displays. The LED driver gives a 3-dB per step display. The lowest step of the display driver is not used; rather a red LOW indicator lights when audio is below the level of the second step. Transistors Q601 and Q602 divert current from the LOW LEDs when any other LED of the display is lit.

Resolution of the linear displays, High Band, Wide Band, and Modulation, has been improved using dither enhancement. With dither, the brightness of the LED is controlled by proximity of the input voltage relative to its voltage threshold. The effect is a smooth transition from step to step as input voltage is changed. U606A, U606B, and associated components comprise the dither generator. Dither output is a triangular wave.

Composite stereo (or mono) is full-wave detected by diodes D605 and D606. U607, U613, Q603, and Q604 are components of a peak sample-and-hold circuit.

Oscillator, U609F, supplies a low-frequency square wave to the Fault indicators, causing them to flash on and off.

Digital multimeter inputs are selected with push buttons located to the right of the multimeter menu. Signals from the push buttons are conditioned by U609A and U609B. U610 is an up/down counter. Binary input to U611 from U610 selects a green menu indicator light, and lights the appropriate decimal point on the numeric readout. The binary lines also go to analog data selectors on the ALC/metering board.

Processing control, R650, is part of the audio processor. (See section 4.2.)

The DPM IN and DPM REF lines are analog and reference voltage inputs to digital multimeter IC U612. They originate from analog data selectors on the ALC/metering board.

4.8 Voltage Regulator Circuit Board

The voltage regulator board is the longer of two boards mounted under the chassis toward the front of the unit. It has switch-mode voltage regulators to provide +12, -12, and 24 volts. It also contains the program detection and automatic carrier control circuits.

Illustration 6–11 and accompanying schematic complement this discussion.

U703E and U703F convert a 38-kHz sine wave from the stereo generator into a synchronization pulse. In the transmitter, synchronization is not used, thus D709 is omitted.

U704 and U705 form a 24-volt switching regulator running at about 35 kHz. U704 is used as a pulse-width modulator; U705 is a high-side driver for MOSFET switch Q701. Supply voltage for the two IC's (approximately 15.5 volts) comes from linear regulator DZ702/Q705. Bootstrap voltage, provided by D710 and C714, allows the

gate voltage of Q701 to swing about 15 volts above the source when Q701 is turned on. Current through the FET is sensed by R738 and R738A. If the voltage between pin 5 and 6 of U705 exceeds 0.23 volts on a current fault, drive to Q701 is turned off. Turn-off happens cycle by cycle. The speed of the turn-off is set by C713.

U706 is a switching regulator for both +12 volts and –12 volts. It runs at about 52 kHz. Energy for –12 volts is taken from inductor L702 during the off portion of the switching cycle. The –12 volts tracks the +12 volts within a few tenths of a volt. There will be no –12 volts until current is drawn from the +12 volts.

Q702, Q703, and Q704 form an active filter and switch, supplying DC voltage to the RF driver, when the Carrier switch is on.

The program detection circuit is made up of U701 and U702. U701A and U701D and associated circuitry discriminate between normal program material and white noise (such as might be present from a studio-transmitter link during program failure) or silence. U701A and surrounding components form a band-pass filter with a Q of 3 tuned to about 5 kHz. U701D is a first-order low-pass filter. Red and green LEDs on the board indicate the presence or absence of program determined by the balance of the detected signals from the two filters. U702 and U701C form a count-down timer. The time between a program fault and shutdown is selected by jumpering pins on header JP701. For times, see section 5.7. The times are proportional to the value of R721 (that is, times can be doubled by doubling the value of R721).

4.9 Power Regulator Circuit Board

The power regulator board is the shorter of two boards mounted under the chassis toward the front of the unit. The board has the isolating diode for the battery input, the switch-mode voltage regulator for the RF power amplifier, and circuitry for PA supply current metering.

Illustration 6–12 and accompanying schematic complement this discussion.

Diode D804, in series with the battery input, together with the AC-supply diode bridge, provides diode OR-ing of the AC and DC supplies.

U801 and U802 form a switching regulator running at about 35 kHz. U801 is used as a pulse-width modulator; U802 is a high-side driver for MOSFET switch Q801. Power for the two IC's comes from the 24-volt supply voltage for the RF driver (available when the Carrier switch is on). The voltage is controlled at 16 volts by zener diode DZ801. Bootstrap voltage provided by D802 and C809 allows the gate voltage of Q801 to swing about 16 volts above the source when Q801 is turned on. Current through the FET is sensed by R812 and R812A. If the voltage from pin 5 to 6 of U802 exceeds 0.23 volts on a current fault, drive to Q801 is turned off. This happens on a cycle-by-cycle basis. The speed of the turnoff is set by C805.

In the transmitter, synchronization is not used, thus D801 is omitted.

U803 and Q802 are used in a circuit to convert the current that flows through metering shunt, R819, into a current source at the collector of Q803. Forty millivolts is developed across R819 for each amp of supply current (.04 ohms x 1 amp). Q803 is biased by U803 to produce the same voltage across R816. The collector current of Q803 is the same (minus base current) as that flowing through

R822 resulting in 40 microamperes per amp of shunt current. R405 on the metering board converts Q803 collector current to 0.1 volt per amp of shunt current (.04 ma X 2.49 k). (See section 5.4.)

4.10 RF Driver

The RF Driver assembly is mounted on a 100 mm x 100 mm plate in the under side of the chassis. The driver amplifies the approximate 20 milliwatts from the frequency synthesizer to about 8 watts to drive the RF power amplifier. A CA2832 hybrid, high-gain, wideband amplifier, operating at about 18 volts, provides about one watt of drive to a single MRF137 MOSFET amplifier. The MRF137 stage operates from a supply voltage of approximately 18 volts.

The circuit board provides for input/output coupling and for power supply filtering.

4.11 RF Amplifier

The RF power amplifier assembly is mounted on back of the chassis with four screws, located behind an outer cover plate. Access the connections to the module by removing the bottom cover of the unit. The RF connections to the amplifier are BNC for the input and output. Power comes into the module through a 5-pin header connection next to the RF input jack.

The amplifier is built around two Phillips BLF278 dual-power MOSFETs rated for 50 volts DC and a maximum power of about 300 watts. When biased for class B, the transistor has a power gain of about 20 dB. (It is biased below class B in the transmitter.)

Input transformer, T1111, is made up of two printed circuit boards. The four-turn primary board is separated from the one-turn secondary by a thin dielectric film. R1112–R1117 are for damping. Trim pot R1111 sets the bias.

Output transformer, T1121, has a one-turn primary on top of the circuit board and a two-turn secondary underneath. Inductors L1121 and L1122 provide power line filtering.

4.12 Chassis and AC Supply

AC power supply components are internal to a switching power supply module. Switching in the power-entry module configures the power transformer for 120 or 240 VAC. See Section 2.2, Power Connections, for switching and fuse information.

4.13 RF Output Filter & Reflectometer

The RF low-pass filter/reflectometer are located in the right-hand compartment on the top of the chassis. See Illustration 6–14 and accompanying schematic for more information.

A ninth-order, elliptic, low-pass filter attenuates harmonics generated in the power amplifier. The capacitors for the filter are circuit board pads.

The reflectometer uses printed circuit board traces for micro-strip transmission lines. Transmission line segments (with an impedance of about 82 ohms) on either side of a 50-ohm conductor provide sample voltages representative of the square root of forward and reverse power.

DC voltages, representative of forward and reflected power, go through a bulkhead filter board to the motherboard, then to the metering board, where they are processed for power control and metering and for SWR metering and protection.

4.14 Receiver Circuit Board Option

This option allows the transmitter to be used as a translator. The receiver board receives terrestrially fed RF signal and converts it to composite audio which is then fed into the exciter board. Microprocessor controlled phase lock loop technology ensures the received frequency will not drift, and multiple IF stages ensure high adjacent channel rejection. Refer to illustrations 4–6, 6–16 and its schematic for the following discussion.

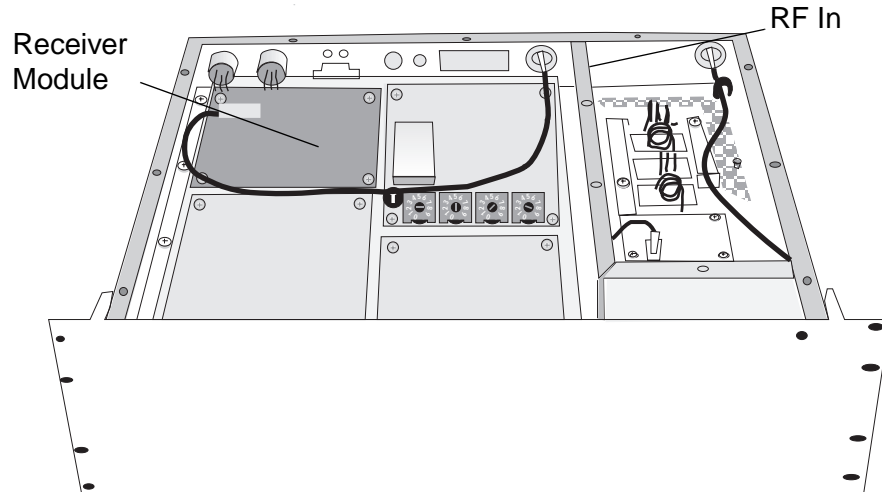

Illustration 4-5 Receiver Board

The square shaped metal can located on the left side of the receiver board is the tuner module. The incoming RF signal enters through the BNC connector (top left corner) and is tuned through the tuner module. Input attenuation is possible with jumper J1 on the top left corner of the receiver board. Very strong signals can be attenuated 20 dB automatically by placing the jumper on the left two pins (“LO” position). An additional 20 dB attenuation is also available with the jumpers in the top left corner of the board. The frequencies are tuned by setting switches SW1 and SW2 (upper right corner). These two switches are read upon power up by the microprocessor (U4). The microprocessor then tunes the synthesizer IC SA1057

(U3) to the selected frequency. The switches frequency range is 87.9 Mhz at setting “00” to 107.9 Mhz at setting “64”. Other custom ranges are available.

The synthesizer chip works on a phase lock loop system. It receives the frequency information from pin 6 of the tuner module, then goes through a FET buffer amplifier (Q2) on its way to synthesizer IC (U3). The synthesizer feeds back a DC voltage through two resistors to pin 4 of the tuner module. Different frequencies cause different tuning voltages to go to the tuner module to tune it on frequency. The frequency synthesizer locks on to the exact frequency needed and adjusts the DC voltage accordingly. The microprocessor tunes the frequencies of the synthesizer IC, but the DC tuning voltage is somewhat dependent on the tuner module.

Generally, the voltage is around 0.5 volt DC for tuning 88.1 MHz, and from 5.5 to 6.5 volts DC for tuning 107.9 MHz. The 10.7 MHz IF frequency comes out of the tuner module on pin 5 and is coupled into the first filter FL1; passes through FL1 and into the IF decoder system of IC LM1865 (U1). The FL1 filter sets the bandwidth or everything outside of the bandwidth depending on the filter that is selected. It could be a bandwidth of 180 kHz where everything outside of that is filtered out depending on the filter characteristics. A second filter (F3) is available when the signal has a great amount of interference from an adjacent signal. In such a case, remove the jumper cap that is in the F3 position, then remove the ceramic filter that is in the F4 storage position and place it into the F3 position.

Then the signal goes to a buffer gain stage at pin 1 of LM1865 (U1). From there the signal passes through F2, which is a second filter for further removal of unwanted products, and then it goes on to the IF of that chip. The quadrature coil L4 is tuned to 10.7 MHz as per calibration procedures. This results in a low distortion of around 0.2 to 0.3% on the audio. The audio, still a composite at this point, will come out of pin 15 of that IC (U1) and go to the first buffer U9. Then it goes through a compensation network R54 and C26, and on to the stereo decoder chip at pin 2 of U5.

When a stereo signal is present, Led 1 illuminates which indicates that left and right audio is available. Then the stereo signals go to gain stages U6A and U6B and out to the RCA jacks on the back of the cabinet. These can be used for off-air monitoring of the audio signal. Incoming frequency can be monitored from the frequency monitor BNC jack on the back. The stereo buffer U9, stereo decoder U5, and gain stages U6A and U6B have no effect on the signal that goes through the transmitter. This section along with the composite signal coming out of pin 15 of LM1865 (U1) is totally separate from the transmitter section.

A muting circuit, consisting of C22, a 1N914 diode, R14, and variable resistor R15 mutes the output when a signal is too weak to be understood. The strength of the signal muted is determined by the adjustment of R15. Any signal below the setting of R15 is shorted to +VCC through C22 by the current drawn through R14 and the diode. The audio signal above this setting goes through C17 to the connector P3.

The P3 connector block allows jumpering to either internal circuitry or to external signal processing such as advertisement injection or other forms of altering the signal. If the jumper is installed for internal circuitry, the signal will go through R39 to the input of U2A. This is a buffer that drives the R20 pot located on the top

left hand corner of the board. R20 sets signal gain for 100% modulation if adjusted correctly with a full incoming 75 kHz deviation signal. Then the signal goes through R21, R22, and C20 which, along with adjustable pot R24 and C21, forms a compensation network with some phase shifting. This allows the best stereo separation possible by adjusting and compensating for differences in FM exciter boards. The signal is buffered through U2B and finally reaches the output connectors P1 and P2, and on to the transmit circuitry.

The power supply is fairly straight forward. The incoming 12 volt supply goes to a 7809, 9 volt regulator (VR1) which supplies all 9-volt needs on the board. The 9 volts also supplies a 7805, 5 volt regulator (VR2) which supplies all 5-volt needs on the board. Plus and minus 12 volts from the motherboard is filtered and supplies various needs on the board. Finally there is a precision reference voltage supplied through R50 by U7 and U8. These two 2.5 volt reference shunts act very much like a very accurate Zener diode to provide precision 5 volts to the metering board.

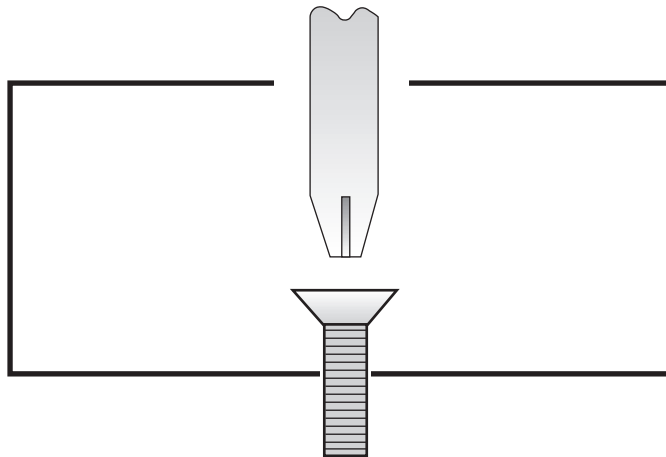

Section 5—Adjustments and Tests

This section describes procedures for (1) advanced users who may be interested in customizing or optimizing the performance of the transmitter and (2) service personnel who want to return the transmitter to operational status following a maintenance procedure.

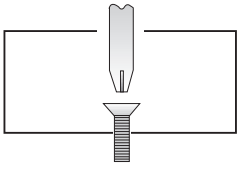

5.1 *Audio Processor Adjustments*

5.1.1 **Pre-Emphasis Selection**

Select the pre-emphasis curve (75 μ sec, 50 μ sec, 25 μ sec, or Flat) by jumpering the appropriate pins of header JP1 on the audio processor board. (See Section 2.9, Audio Monitor Connections.) If you change the pre-emphasis, change the de-emphasis jumpers, JP203 and JP204 on the Stereo Generator board, to match. (See Section 2.8, Composite Input Connection)

5.1.2 **Pre-Emphasis Fine Adjustment**

Trim potentiometers, R29 and R65, (for left and right channels, respectively) provide for fine adjustment of the pre-emphasis. Set the potentiometers to bring the de-emphasized gain at 10 kHz equal to that of 400 Hz. (At the proper setting, 15.0 kHz will be down about 0.7 dB.)

When making these adjustments, it is important that you keep signal levels below the processor gain-control threshold.

A preferred method is to use a precision de-emphasis network in front of the audio input. Then, use the non-de-emphasized (flat) output from the FM modulation monitor for measurements.

5.2 *Stereo Generator Adjustments*

5.2.1 **Separation**

Feed a 400-Hz sine wave into one channel for at least 70% modulation. Observe the classic single-channel composite stereo waveform at TP301 on the RF Exciter circuit board. Adjust the Separation control for a straight centerline.

Since proper adjustment of this control coincides with best stereo separation, use an FM monitor to make or confirm the adjustment

5.2.2 **Composite Output**

You can make adjustments to the composite output in two ways:

- Using a modulation monitor
- Using Bessel nulls

5.2.2.1 **Using a Modulation Monitor**

1. Set the Stereo-Mono switch to Mono.
2. Check that the setting of the Modulation compensation control (see Section 2.3.1, Modulation Compensator) on the RF Exciter circuit board, falls within the range specified for the frequency of operation.
3. Feed a sine wave signal of about 2.5 kHz into the left channel at a level sufficient to put the wideband gain-reduction indicator somewhere in the middle of its range.
4. Set the Composite level control to produce 90% modulation as indicated on an FM monitor.
5. Apply pink noise or program material to the audio inputs and confirm, on both Mono and Stereo, that modulation peaks are between 95% and 100%.

5.2.2.2 Using Bessel Nulls

Done properly, the Bessel nulls method provides greater accuracy than the average modulation monitor. The following procedure sets the gain-control threshold for 90% modulation.

1. Set the Stereo-Mono switch to Mono.
2. Check that the setting of the Modulation compensation control, R351 on the RF Exciter circuit board, falls within the range specified for the frequency of operation. (See Section 2.3.1, Modulation Compensator)
3. Feed a 2.807-kHz sine wave signal into the left channel at a level sufficient to put the wideband gain-reduction indicator somewhere in the middle of its range. The modulation setting will be only as precise as the frequency of the sine wave; a 1% error in frequency will result in a 1% error in deviation.
4. Couple a shortwave receiver, tuned to one-tenth the operating frequency (8.70 MHz to 10.80 MHz), to TP302 on the RF Exciter circuit board. (In most cases, there need not be a direct connection.) The receiver must have either a narrow IF bandwidth setting or a BFO (beat frequency oscillator).
5. Adjust the Composite level control to null the carrier.
 - a. If using a BFO, set the BFO for a low-frequency audio tone. Listen for this tone to disappear at the carrier null.
 - b. Without a BFO, watch the signal-level indicator on the receiver or determine, by ear, the point at which the carrier nulls. (This practice only works if the bandwidth is narrow enough to discriminate against the 2.8-kHz sidebands.)
6. Apply pink noise or program material to the audio inputs and confirm, for both Mono and Stereo, that modulation peaks are between 95% and 100%.

5.2.3 19-kHz Level

Adjust the 19-kHz pilot for 9% modulation as indicated on an FM modulation monitor.

(The composite output should be set first, since it follows the 19-kHz Level control.)

5.2.4 19-kHz Phase

1. Apply a 400-Hz audio signal to the left channel for at least 70% modulation.
2. Look at the composite stereo signal at TP301 on the RF Exciter circuit board with an oscilloscope, expanding the display to view the 19-kHz component on the horizontal centerline.
3. Switch the audio to the right-channel input. When the 19-kHz Phase is properly adjusted, the amplitude of the 19-kHz will remain constant when switching between left and right.
4. Recheck the separation adjustment as described in Section 5.2.1.

5.3 *Frequency Synthesizer Adjustments*

5.3.1 Frequency Channel Selections

Refer to Section 2.3, Frequency (Channel) Selection.

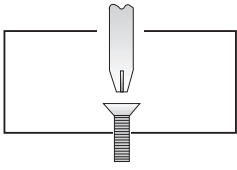

5.3.2 Modulation Compensator

Refer to Section 2.3, Frequency (Channel) Selection.

5.3.3 Frequency Measurement and Adjustment

Next to the 10.24-MHz crystal on the RF Exciter board is a 5.5–18 pF ceramic trimmer capacitor (C303). Use C303 to set the frequency of the 10.24-MHz crystal while observing the output frequency of the synthesizer.

Use one of three methods for checking frequency:

- Use an FM frequency monitor.
- Couple a frequency counter of known accuracy to the output of the synthesizer and observe the operating frequency. Or connect a counter to TP302 and measure one-tenth operating frequency. (Do not connect to the 10.24-MHz clock circuit.)
- Use a shortwave receiver and test point TP301. This method will, in most cases, give better accuracy than the first two options. To use this method, follow these steps:
 1. Temporarily set the synthesizer to 100.0 MHz.
 2. Tune a shortwave receiver to a 10-MHz standard such as WWV or JJY.
 3. Loosely couple the receiver to TP302 so that the 10-MHz signal strength from TP302 is about equal to that being received from the standard station. [In most cases, setting the receiver (if it's a portable, such as the Sony® 2010) on top of the transmitter with the receiver antenna several centimeters (a few inches) from the TP302 test point, will be about right.]
 4. Use the C7 trimmer capacitor to “zero beat” the two signals.

5.3.4 FSK Balance Control

An FSK signal (used for automatic identification of FM repeaters) shifts the frequencies of the 10.24-MHz crystal reference oscillator and the VCO.

Use an oscilloscope to observe the cathode end of D303. With no program, the pulse will be less than 1 μ sec wide. With an FSK input (a 20-Hz square wave at the FSK input will work), set trim pot R356 for minimum pulse width.

The setting will vary slightly with operating frequency.

5.4 Metering Board Adjustments

5.4.1 Power Calibrate

While looking at RF Power on the digital panel meter, set the Power Calibrate trim potentiometer to agree with an external RF power meter.

5.4.2 Power Set

With the front panel RF Output control fully clockwise, adjust the Power Set trim pot to 10% more than the rated power (275 watts for the FM250ET) as indicated on an accurate external watt meter. If the authorized power is less than the maximum watts, you may use the Power Set to limit the range of the RF Output control.

5.4.3 SWR Calibrate

When the Carrier switch is off, or the RF power is less than about 5 watts, the SWR circuit automatically switches to a calibrate-check mode. (See Section 4.5, Metering Circuit Board, for more information.)

Set the digital panel meter to read SWR. With the Carrier switch off, set the SWR CAL trim pot to read 1.03.

5.4.4 PA Current Limit

Since it may not be practical to increase the PA current to set the PA Current Limit control, you may use this indirect method.

With the carrier turned off, look at the DC voltage at the right end of R413 on the Metering board. The current limit, in amperes, will be 0.35 amps higher than ten times this voltage. For example, for a current limit of 7.35 amps, adjust the PA Current Limit control for 0.7 volts at R413 ; or 0.565 volts for 6.0 amps. Set the current limit for 12 amperes or 1.165 volts.

5.5 *Motherboard Adjustments*

For Normal-Bypass switch setting, see Section 2.10.

5.6 *Display Modulation Calibration*

The Modulation Calibrate trim pot sets the sensitivity of the front panel Modulation bar graph display.

This adjustment may be made only after the Output trim pot on the Stereo Generator board has been set. (See Section 5.2.4.)

1. Set the Stereo-Mono switch to Mono.
2. Feed a sine wave source of about 2.5 kHz into the left channel at a level sufficient to put the wideband gain-reduction indicator somewhere in the middle of its range.
3. Set the Modulation Calibrate trim pot so that the “90” light on the front panel Modulation display just begins to light.

5.7 *Voltage Regulator Adjustments*

JP701, a 10-pin header on the Voltage Regulator board, sets the time between program failure and carrier turnoff. Pins 1 and 2 are the two pins closest to the edge of the board. The times are approximate. See Sections 2.11, 2.12, and 4.8 for additional information.

1. Short pins 1 and 2 for a 30-second delay.
2. Short pins 3 and 4 for a 2-minute delay.
3. Short pins 5 and 6 for a 4-minute delay.
4. Short pins 7 and 8 for an 8-minute delay.

You may select other times by changing the value of R721. The time is proportional to the resistance.

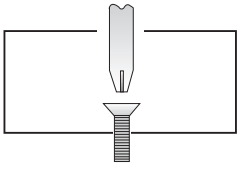

5.8 Performance Verification

Measure the following parameters to receive a comprehensive characterization of transmitter performance:

- Carrier frequency
- RF output power
- RF bandwidth and RF harmonics (see section 5.11)
- Pilot frequency, phase, and modulation percentage
- Audio frequency response
- Audio distortion
- Modulation percentage
- FM and AM noise
- Stereo separation between left and right
- Crosstalk between main channel and subcarrier
- 38-kHz subcarrier suppression

In addition to the above tests, which pertain to signal quality, a complete check of the unit will include items listed in 5.20.

5.8.1 Audio Proof-of-Performance Measurements

References to “100%” modulation assume 9% pilot and 91% for the remainder of the composite stereo signal.

Because the audio processing threshold is at 90% modulation, it is not possible to make audio proof-of-performance measurements at 100% modulation through the audio processor. Instead, audio data for 100% modulation is taken from the input of the stereo generator (SW501 on Motherboard set for Bypass). Then, data, including the audio processor (SW501 set for Normal), is taken at a level below the audio processing threshold.

5.8.2 De-emphasis Input Network

A precision de-emphasis network, connected between the test oscillator and the audio input of the transmitter, can be very helpful when making the audio measurements. Note that the input impedance of the transmitter or the source impedance of the test oscillator can affect network accuracy. With the de-emphasis network, oscillator level adjustments need only accommodate gain errors, instead of the whole pre-emphasis curve.

5.9 Carrier Frequency

Carrier frequency is measured at the output frequency with a frequency monitor or suitable frequency counter.

To adjust frequency, see 5.3.3. (FCC tolerance ± 2000 Hz per FCC Part 73.1540 and 73.1545.)

5.10 Output Power

The output power reading on the front panel display should be 90–105% of the actual value. For a more precise measurement, use a watt meter in the RF output line. See sections 5.4.1 and 5.4.2 for setting power.

5.11 RF Bandwidth and RF Harmonics

You can observe RF bandwidth and spurious emissions with an RF spectrum analyzer.

In the Stereo mode, feed a 15.0-kHz audio signal into one channel to provide 85% modulation as indicated on a monitor. Doing so produces 38% main, 38% stereo subcarrier, and 9% pilot per FCC Part 2.1049. As an alternative, use pink noise into one channel.

Using a spectrum analyzer, verify the following (per FCC 73.317):

1. Emissions more than 600 kHz from the carrier are at least $43 + 10\log(\text{power, in watts})$ dB down (58 dB for 30 watts, 63 dB for 100 watts, 67 dB for 250 watts). The scan should include the tenth harmonic.
2. Emissions between 240 kHz and 600 kHz from the carrier are down at least 35 dB.
3. Emissions between 120 kHz and 240 kHz from the carrier are down at least 25 dB.

5.12 Pilot Frequency

The pilot frequency should be within 2 Hz of 19 kHz. (FCC Part 73.322.) Using a frequency counter, measure 1.9 MHz at pin 1 of U209 on the Stereo Generator board. A 200-Hz error here corresponds to a 2-Hz error at 19 kHz. If the frequency is off by more than 50 Hz, you may change the value of C213. (Changing C213 from 56 pF to 68 pF lowers the 1.9 MHz by about 35 Hz.)

5.13 Audio Frequency Response

For the response tests, take the readings from an FM modulation monitor.

Make audio frequency response measurements for left and right channels at frequencies of 50 Hz, 100 Hz, 400 Hz, 1 kHz, 5 kHz, 10 kHz, and 15 kHz. See Sections 5.8.1 and 5.8.2.

5.14 Audio Distortion

Make distortion measurements from the de-emphasized output of an FM modulation monitor.

Make audio distortion measurements for left and right channels at frequencies of 50 Hz, 100 Hz, 400 Hz, 1 kHz, 5 kHz, 10 kHz, and 15 kHz. See Sections 5.8.1 and 5.8.2.

5.15 Modulation Percentage

While feeding an audio signal into the left channel only, confirm that the total modulation percentage remains constant when switching between Mono and Stereo.

Measure modulation percentage with an FM modulation monitor, or by using an HF receiver and Bessel nulls. See Section 5.2.2.

19-kHz pilot modulation should be 9%.

5.16 FM and AM Noise

Take noise readings from a de-emphasized output of a modulation monitor.

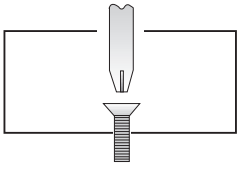

5.17 Stereo Separation

Make left-into-right and right-into-left stereo separation measurements with an FM modulation monitor for frequencies of 50 Hz, 100 Hz, 400 Hz, 1 kHz, 5 kHz, 10 kHz, and 15 kHz.

5.18 Crosstalk

For stereo crosstalk measurements, both left and right channels are fed at the same time. For best results, there needs to be a means of correcting small imbalances in levels and phase. The balance is made at 400 Hz.

5.18.1 Main Channel Into Sub

Feed the left and right channels in phase with audio (L+R) at 50 Hz, 100 Hz, 400 Hz, 1 kHz, 5 kHz, 10 kHz, and 15 kHz at 100% modulation, while observing the stereo subcarrier (L-R) level on an FM modulation monitor.

5.18.2 Sub Channel Into Main

Feed the audio into the left and right channel as above, with the exception of reversing the polarity of the audio of one channel (L-R input). Using the frequencies of 5.18.1 above, observe the main channel (L+R) level with a modulation monitor.

5.19 38-kHz Subcarrier Suppression

With no modulation, but in the Stereo mode, the 38-kHz subcarrier, as indicated on an FM modulation monitor, should be down at least 40 dB.

5.20 Additional Checks

In addition to the tests and adjustments mentioned in this section, the following checks ensure a complete performance appraisal of the transmitter:

1. Perform a physical inspection, looking for visible damage and checking that the chassis hardware and circuit boards are secure.
2. Check the functionality of switches and processing control.
3. Verify that all indicators function.
4. Check the frequency synthesizer lock at 80 MHz and 110 MHz.
5. Measure the AC line current with and without the carrier on.
6. Perform a functional test of the SCA input, Monitor outputs, and the monitor and control function at the 15-pin, D-sub connector.
7. Test the functionality of the FSK circuit.
8. Check the operation and timing of the automatic carrier-off circuitry associated with program failure.
9. Check all metering functions.
10. Test ALC action with PA current overload, SWR, and PLL lock.

Note: FCC type acceptance procedures call for testing the carrier frequency over the temperature range of 0–50 degrees centigrade, and at line voltages from 85% to 115% of rating. (See FCC Part 2.1055.)

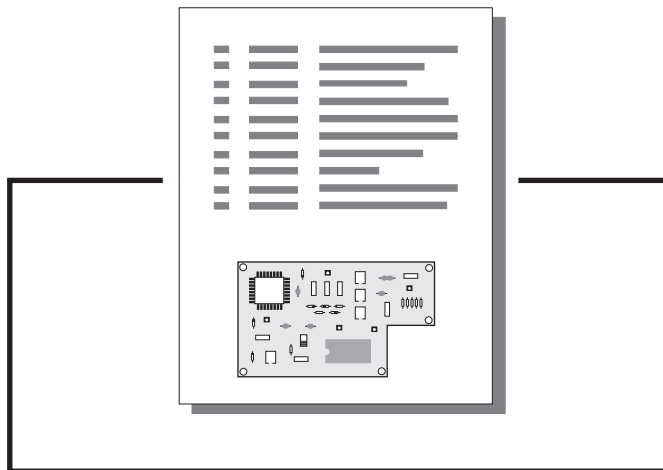

Section 6—Reference Drawings

The illustrations in this section may be useful for making adjustments, taking measurements, troubleshooting, or understanding the circuitry of your transmitter.

6.1 Views

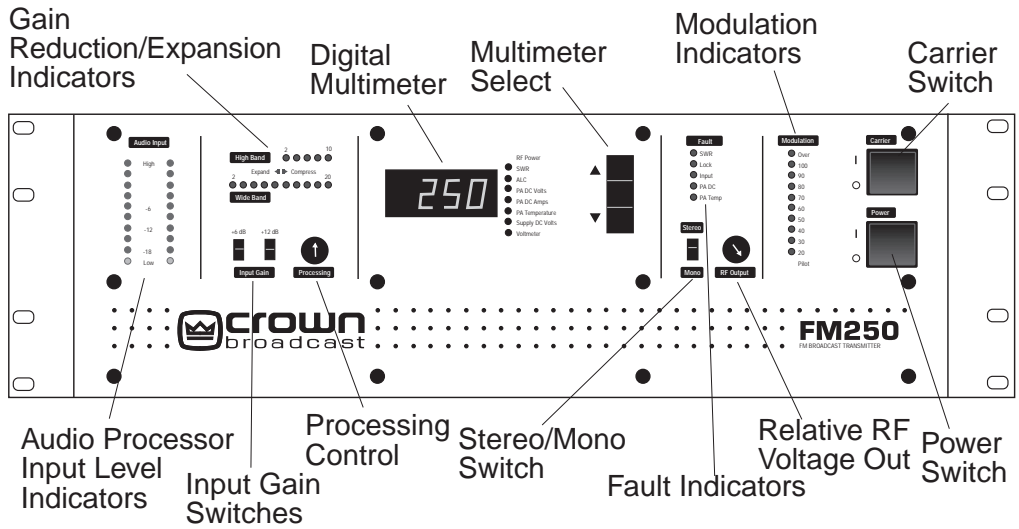

Illustration 6-1 Transmitter Front View

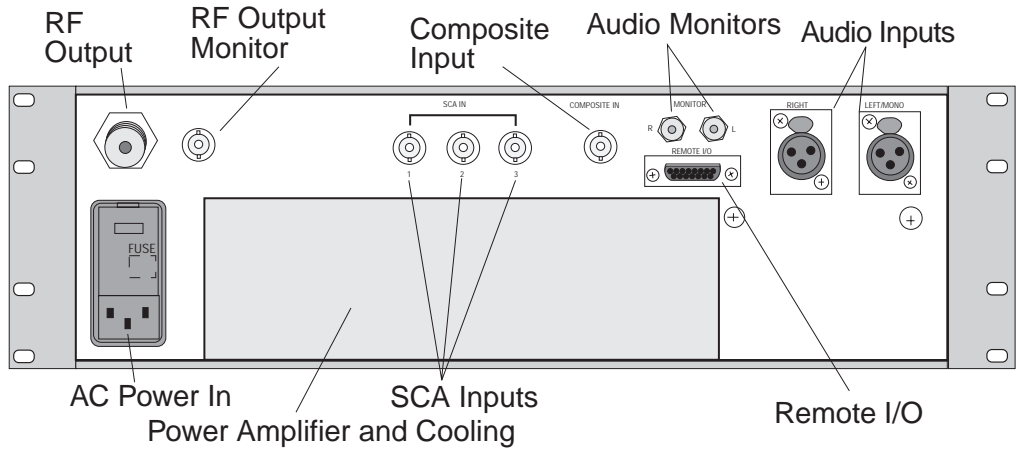

Illustration 6-2 Transmitter Back View

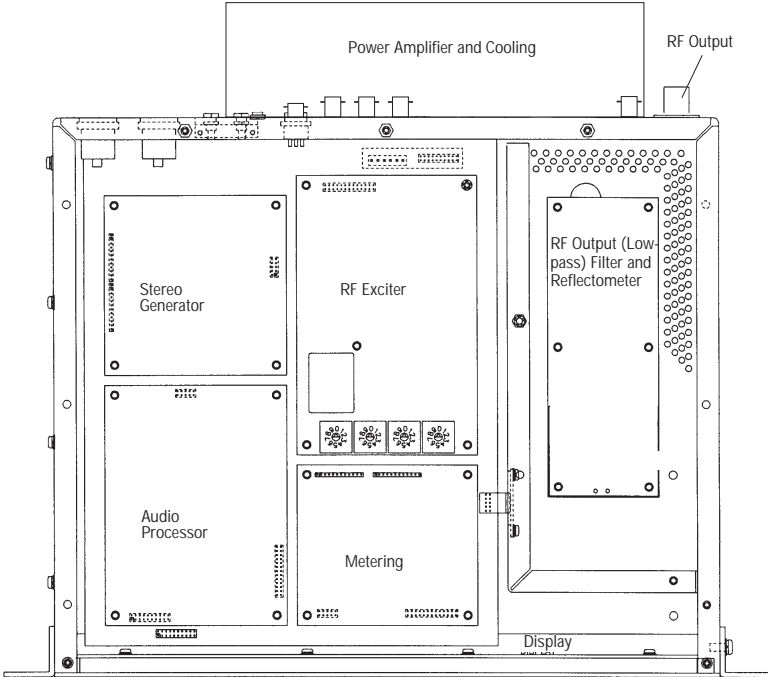

Illustration 6-3 Chassis Top View

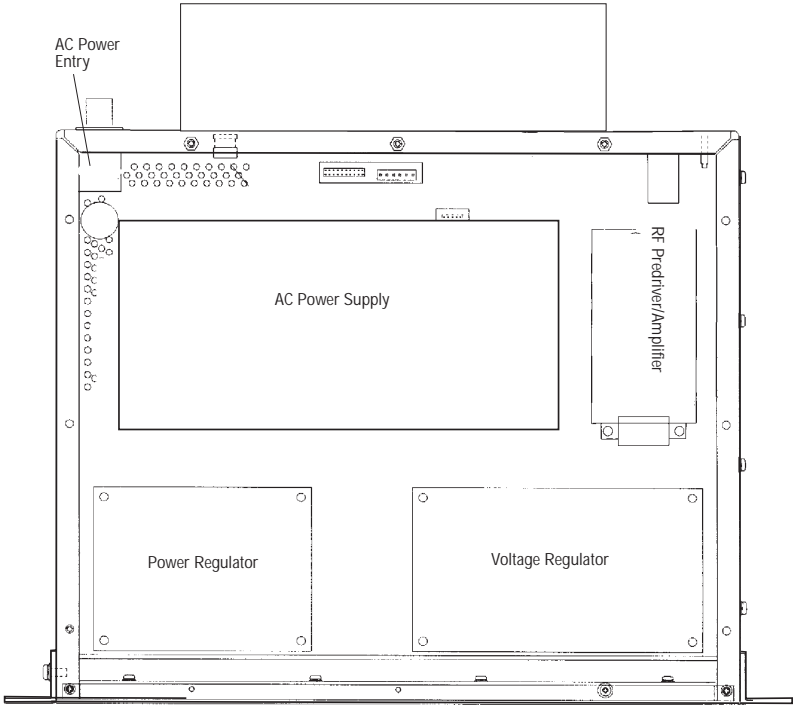

Illustration 6-4 Chassis Bottom View

6.2 Board Layouts and Schematics

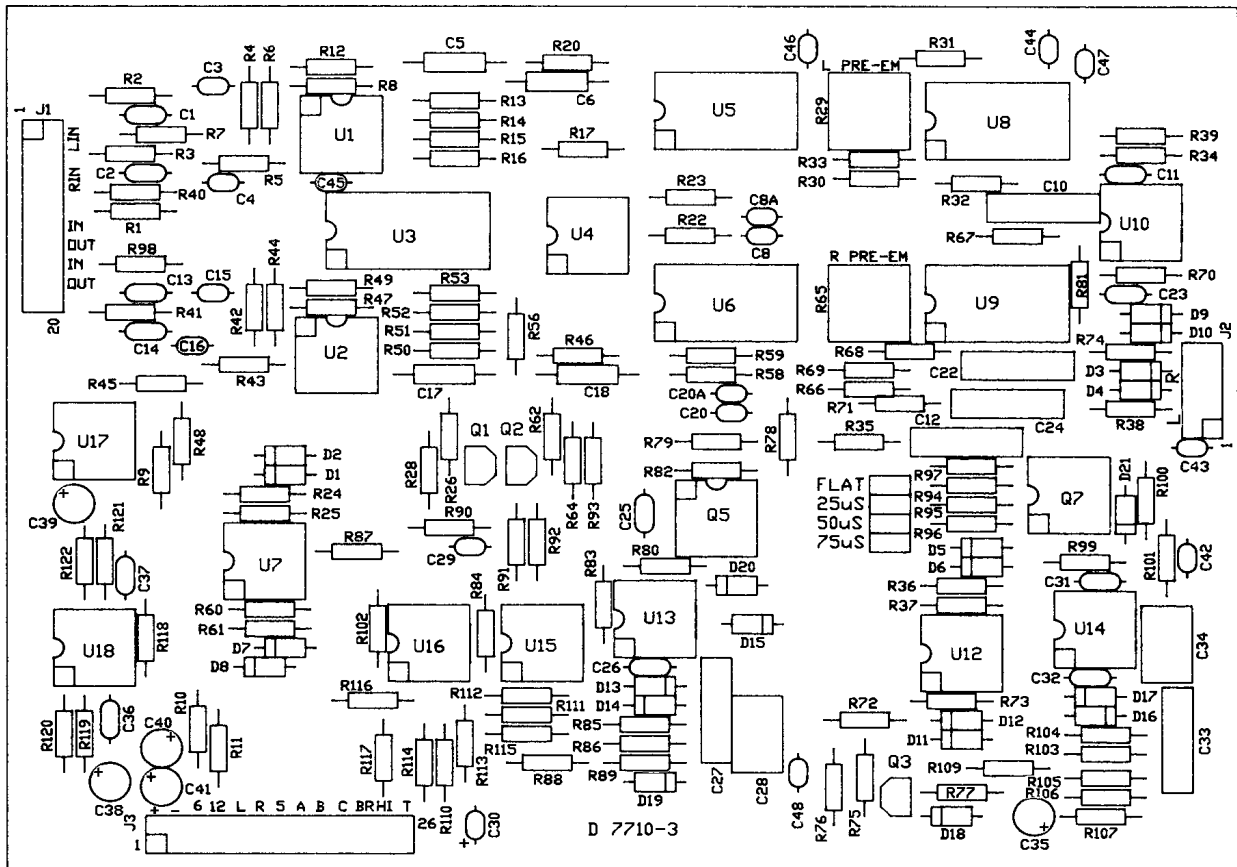
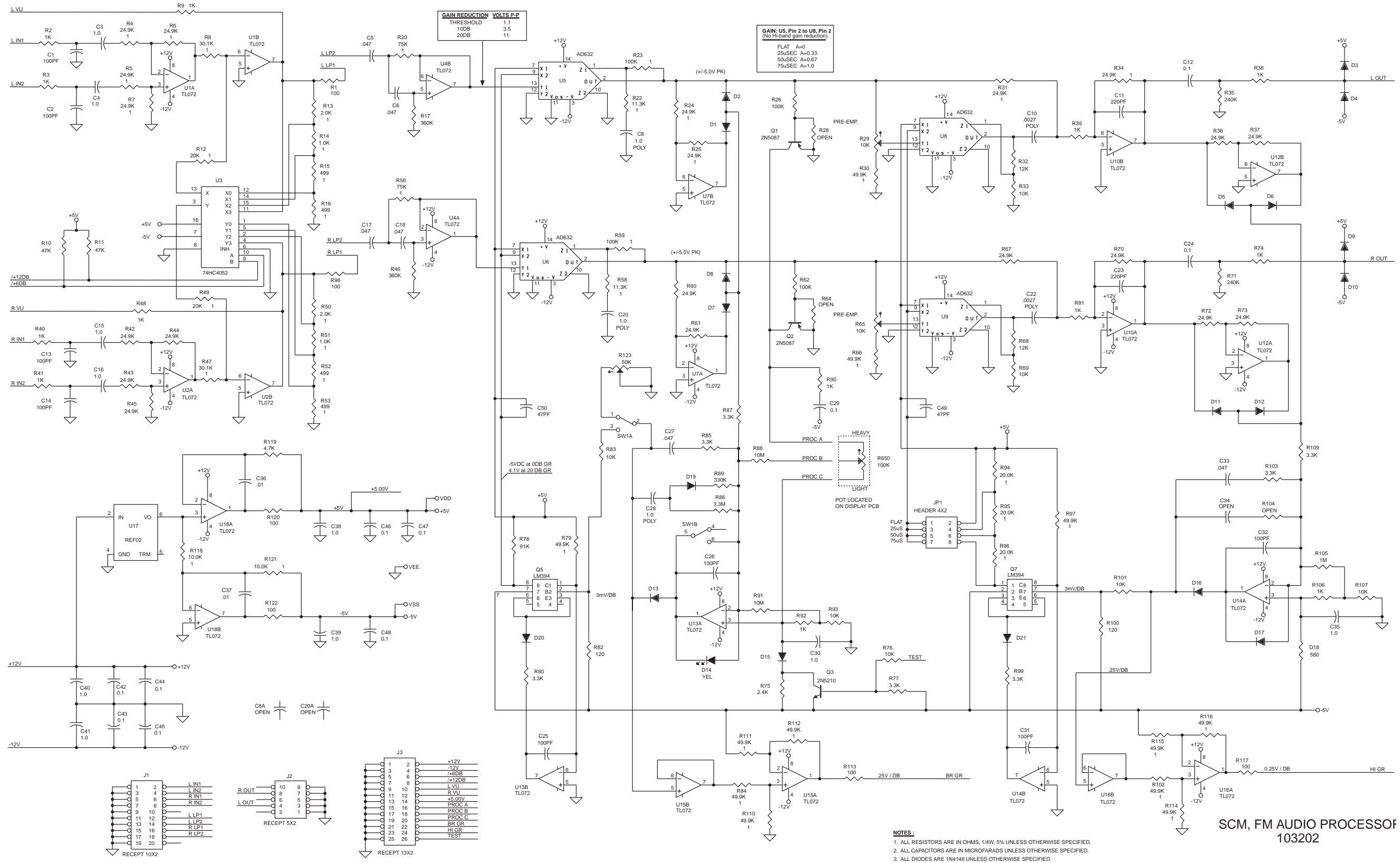

Illustration 6-5 Audio Processor Board



Schematic 6-1 Audio Processor

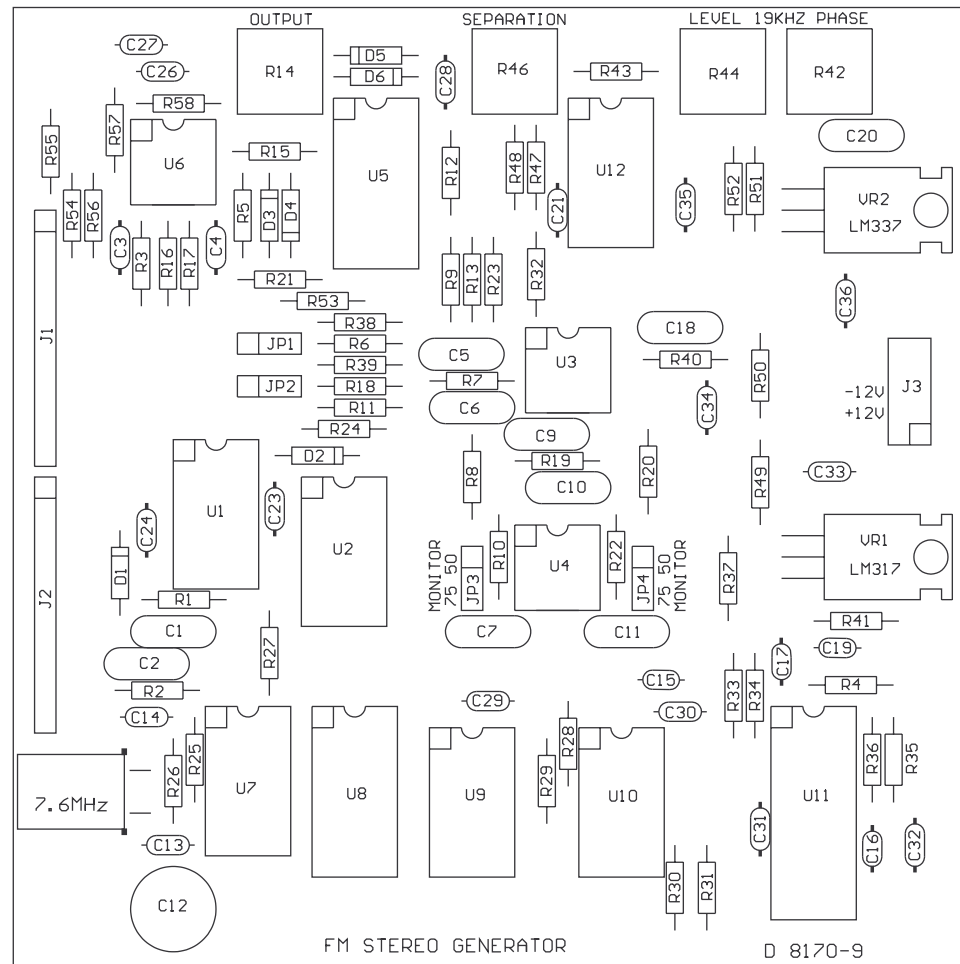
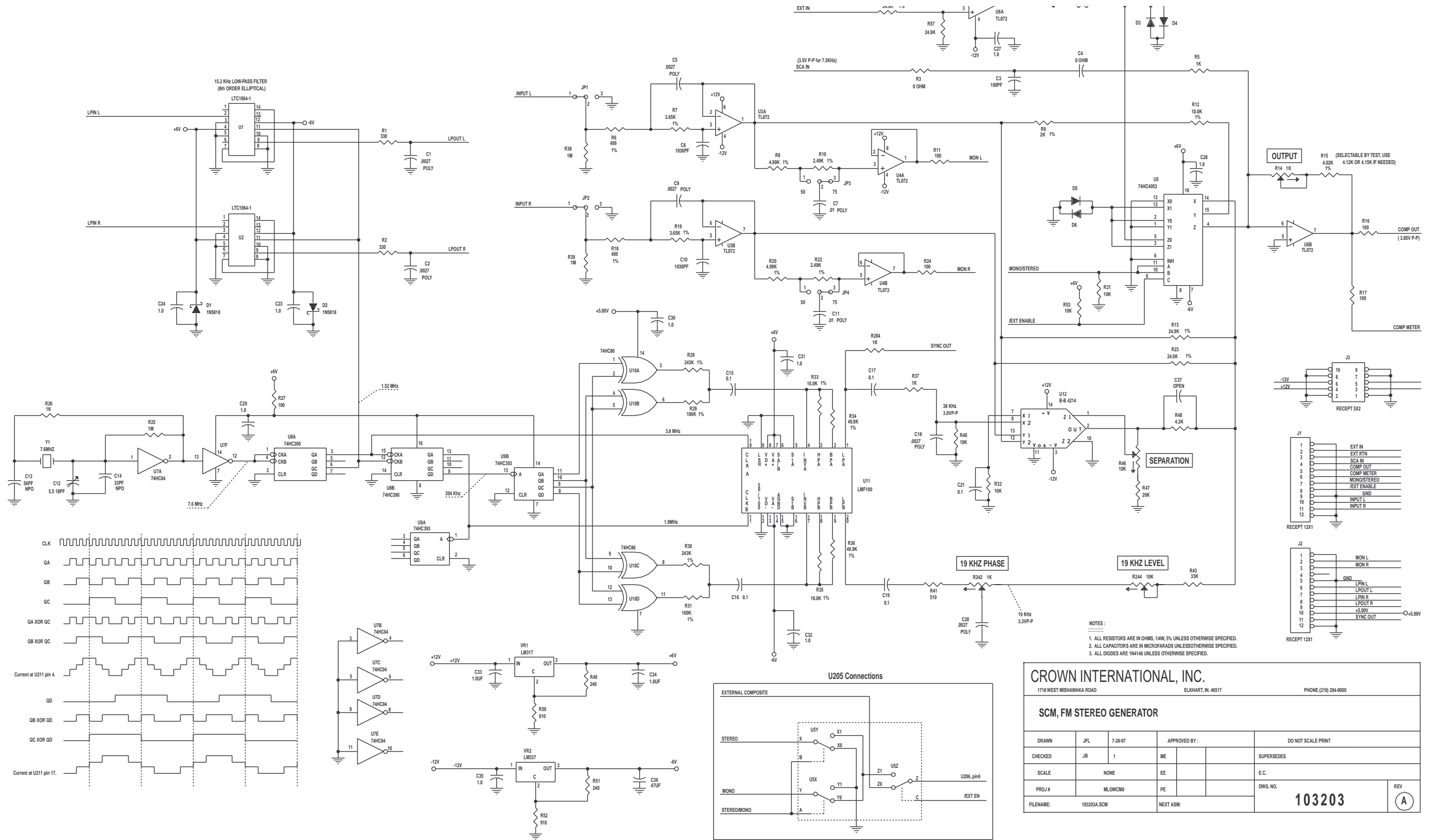
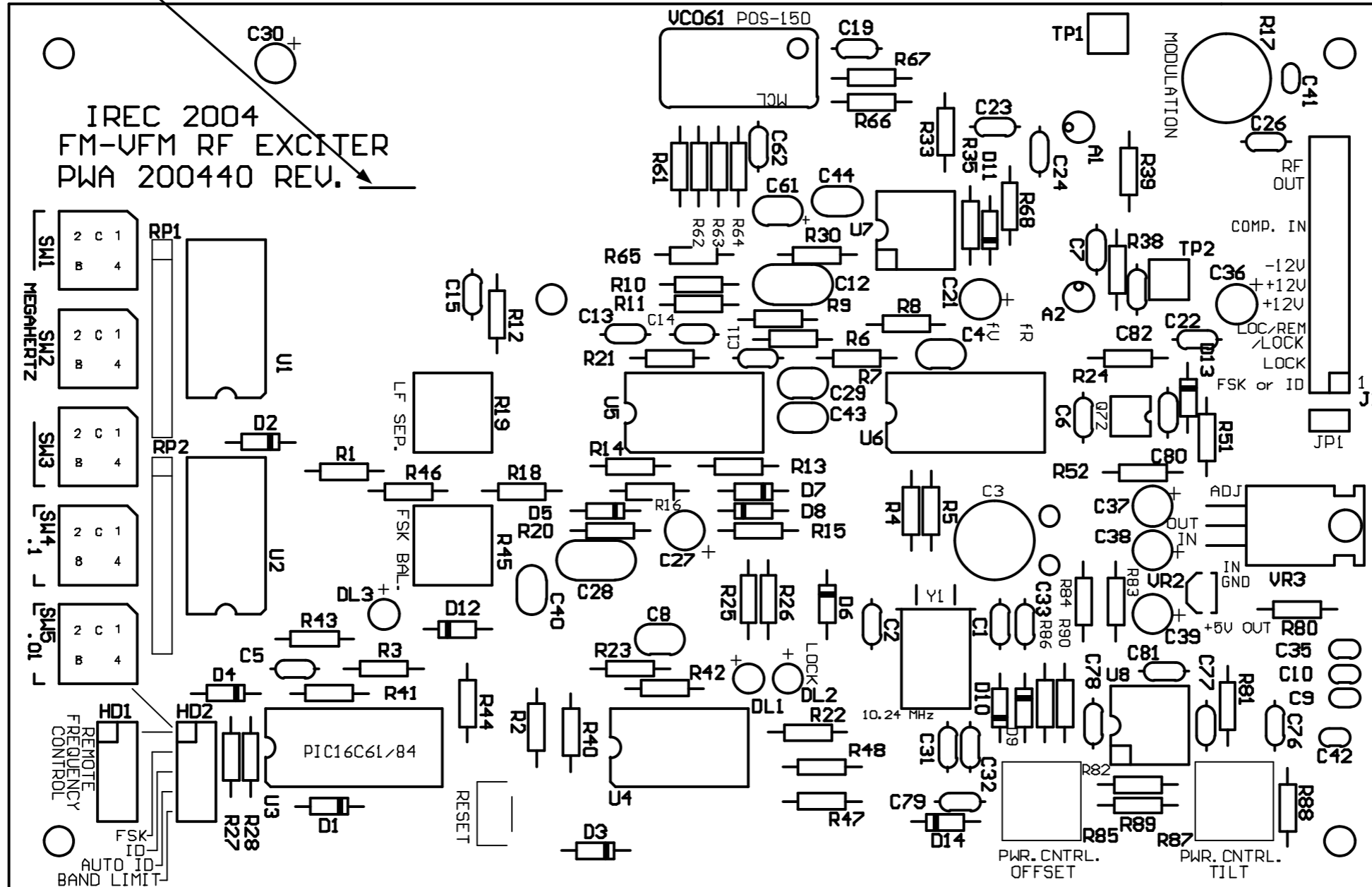

Illustration 6-6 Stereo Generator Board



Schematic 6-2 Stereo Generator

SEE NOTE 10



Top Overlay

TOP SIDE COMPONENT MAP, FM-VFM EXCITER

PWB: 200440-PWB-A.PCB

M200440PT-A.DOC

UNCONTROLLED
UNLESS OTHERWISE MARKED IN RED BY CM AS A CONTROLLED COPY. COPIES OF THESE DOCUMENTS AND ASSOCIATED ELECTRONIC FILES ARE UNCONTROLLED AND ARE FOR REFERENCE ONLY.

THESE DRAWINGS, SPECIFICATIONS AND ASSOCIATED ELECTRONIC FILES ARE THE PROPERTY OF INTERNATIONAL RADIO AND ELECTRONICS CORP., AND SHALL NOT BE REPRODUCED, COPIED, OR USED AS THE BASIS FOR THE MANUFACTURE OR SALE OF APPARATUS OR DEVICES WITHOUT PERMISSION.

SIZE B DWG. NO.

200440-PWA

REV A

SCALE: N/A

PROJECT #: 509

SHEET: 1 OF 1

REVISION HISTORY				APPROVALS			
E. C. N.	REV	DESCRIPTION	DATE	DWN	CHK	CM	PE
	1	FOR PROTOTYPE	01-04-02	DW			
	2	MODIFIED PER MIKE SENEKI	02-06-02	DW			
	3	CHGD R18 PER EAD MRH01. R18 WAS 91K OHM. U5 WAS C 6900-5	06-24-02	DW			
246 A-G	4	R8 WAS 1.0K OHM.	05-23-03	DW			
277	A	PRODUCTION RELEASE	01-29-04	DW		DW	DP

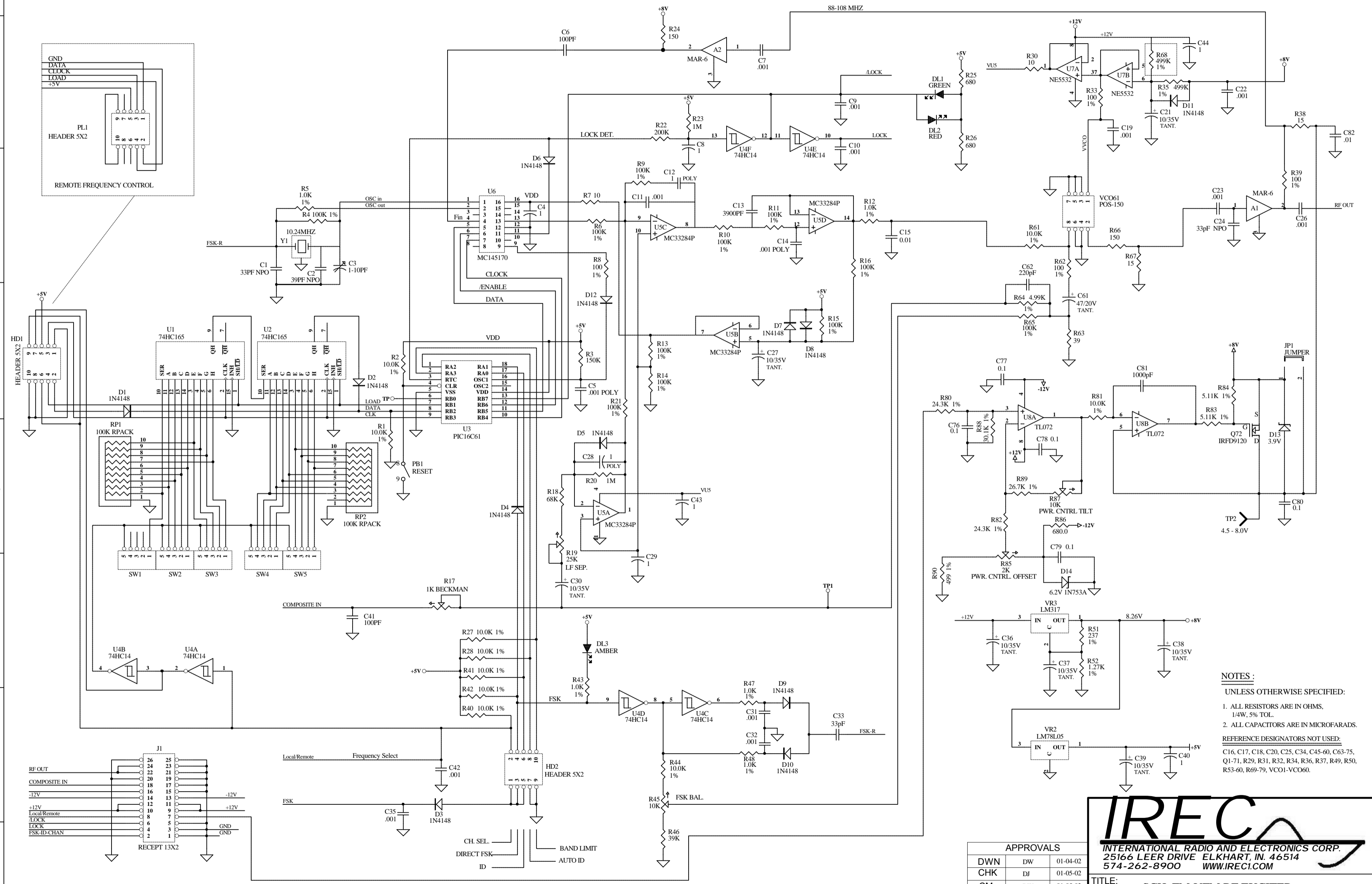

NOTES :
 UNLESS OTHERWISE SPECIFIED:
 1. ALL RESISTORS ARE IN OHMS, 1/4W, 5% TOL.
 2. ALL CAPACITORS ARE IN MICROFARADS.
 REFERENCE DESIGNATORS NOT USED:
 C16, C17, C18, C20, C25, C34, C45-60, C63-75, Q1-71, R29, R31, R32, R34, R36, R37, R49, R50, R53-60, R69-79, VCO1-VCO60.

UNCONTROLLED
 UNLESS OTHERWISE MARKED IN RED INK BY CM AS A CONTROLLED COPY, COPIES OF THESE DOCUMENTS INCLUDING ASSOCIATED ELECTRONIC REPRODUCTIONS ARE FOR REFERENCE ONLY.

THESE DRAWINGS AND SPECIFICATIONS ARE THE PROPERTY OF INTERNATIONAL RADIO CORP. AND SHALL NOT BE REPRODUCED, COPIED OR USED AS THE BASIS FOR THE MANUFACTURE OR SALE OF APPARATUS OR DEVICES WITHOUT PERMISSION.



APPROVALS		
DWN	DW	01-04-02
CHK	DJ	01-05-02
CM	DW	01-05-02
PE	DP	01-05-02
DISTRIBUTION		
K		
FILENAME:		

TITLE: SCH, FM-VFM RF EXCITER		REV A
SIZE C	DWG. NO. 200440-SCH	REV A
SCALE: NONE	PROJ. NO. 509	SHEET 1 OF 1

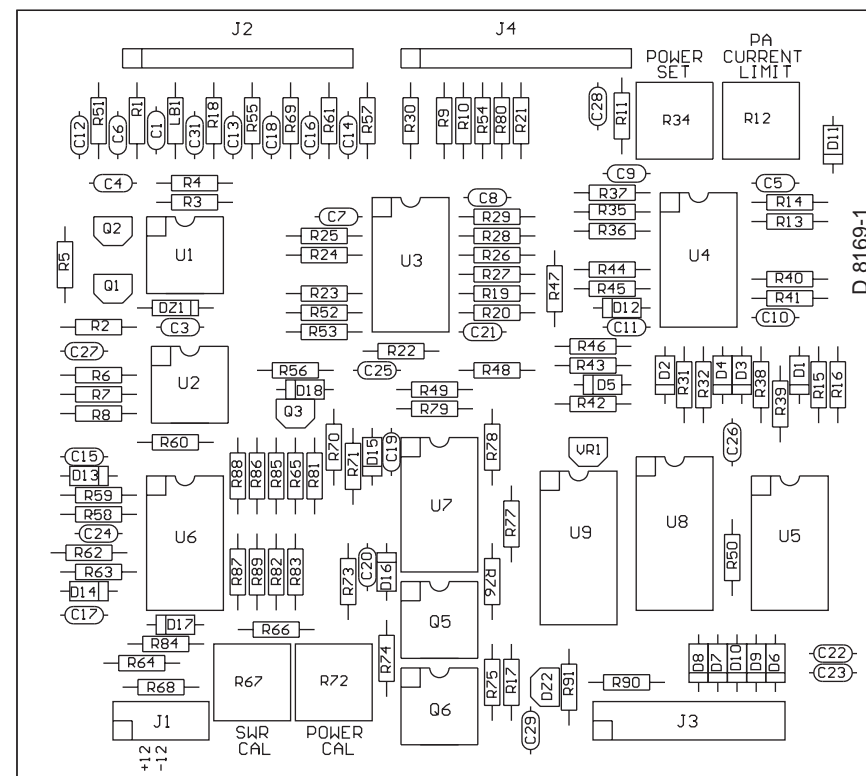
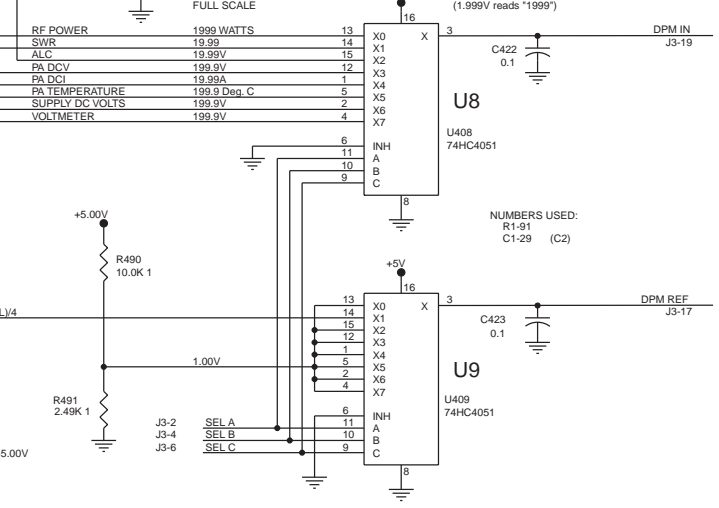
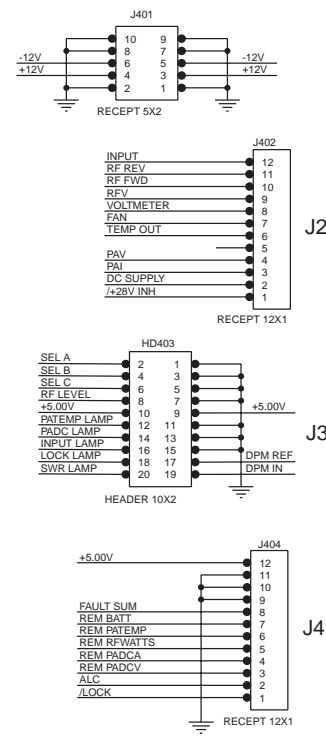
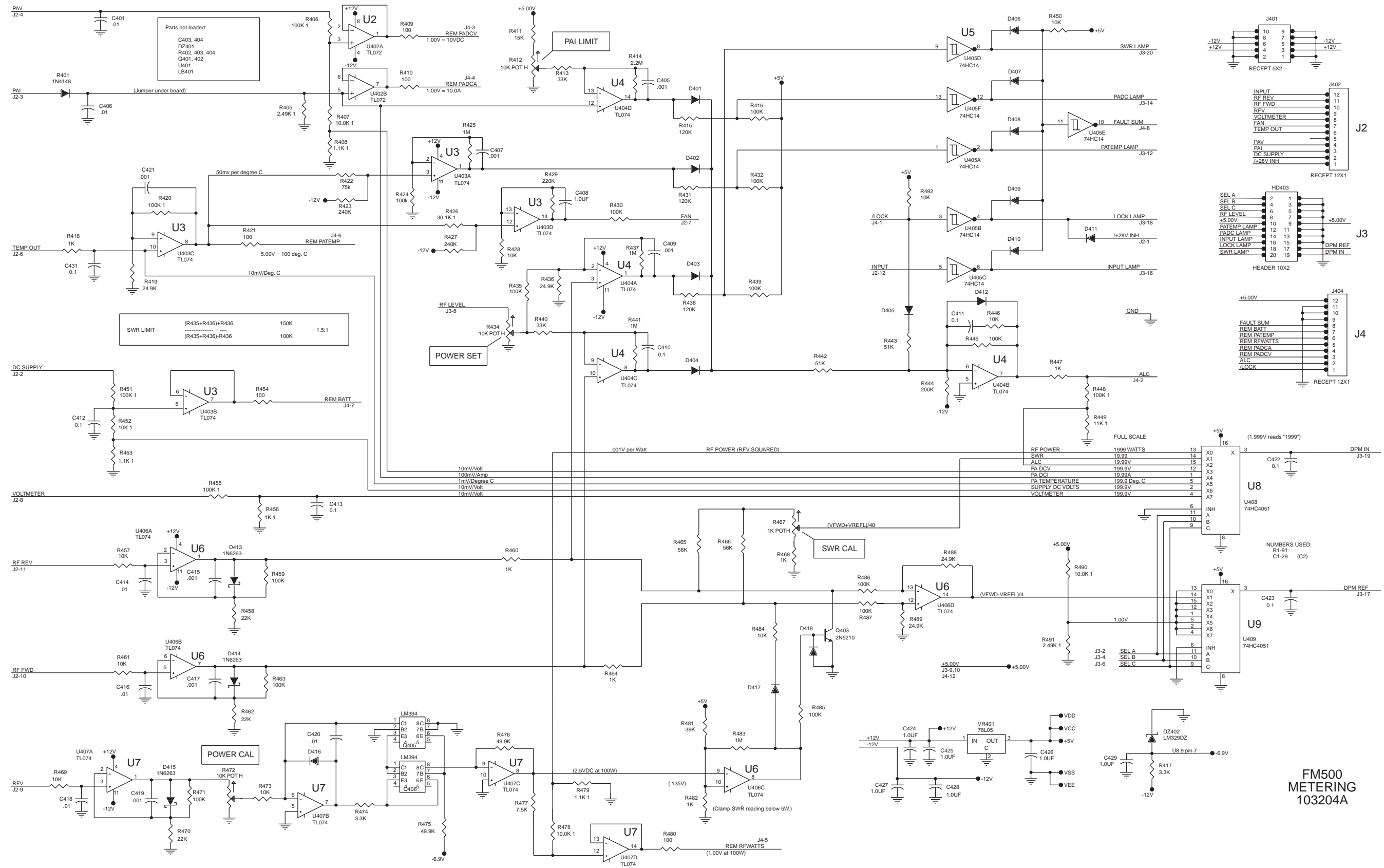
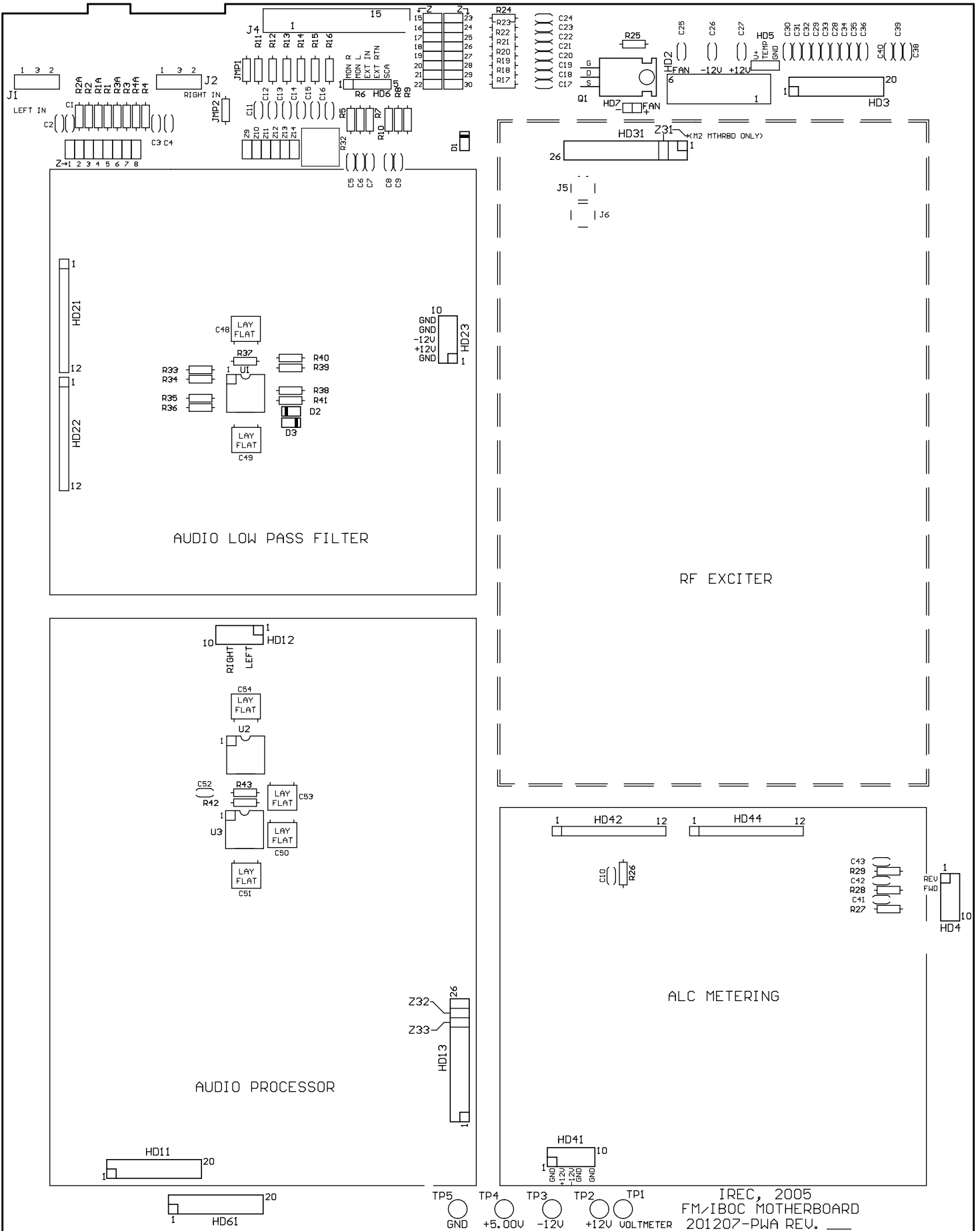

Illustration 6-8 RF Metering Board



Schematic 6-4 Metering

FM500
METERING
103204A



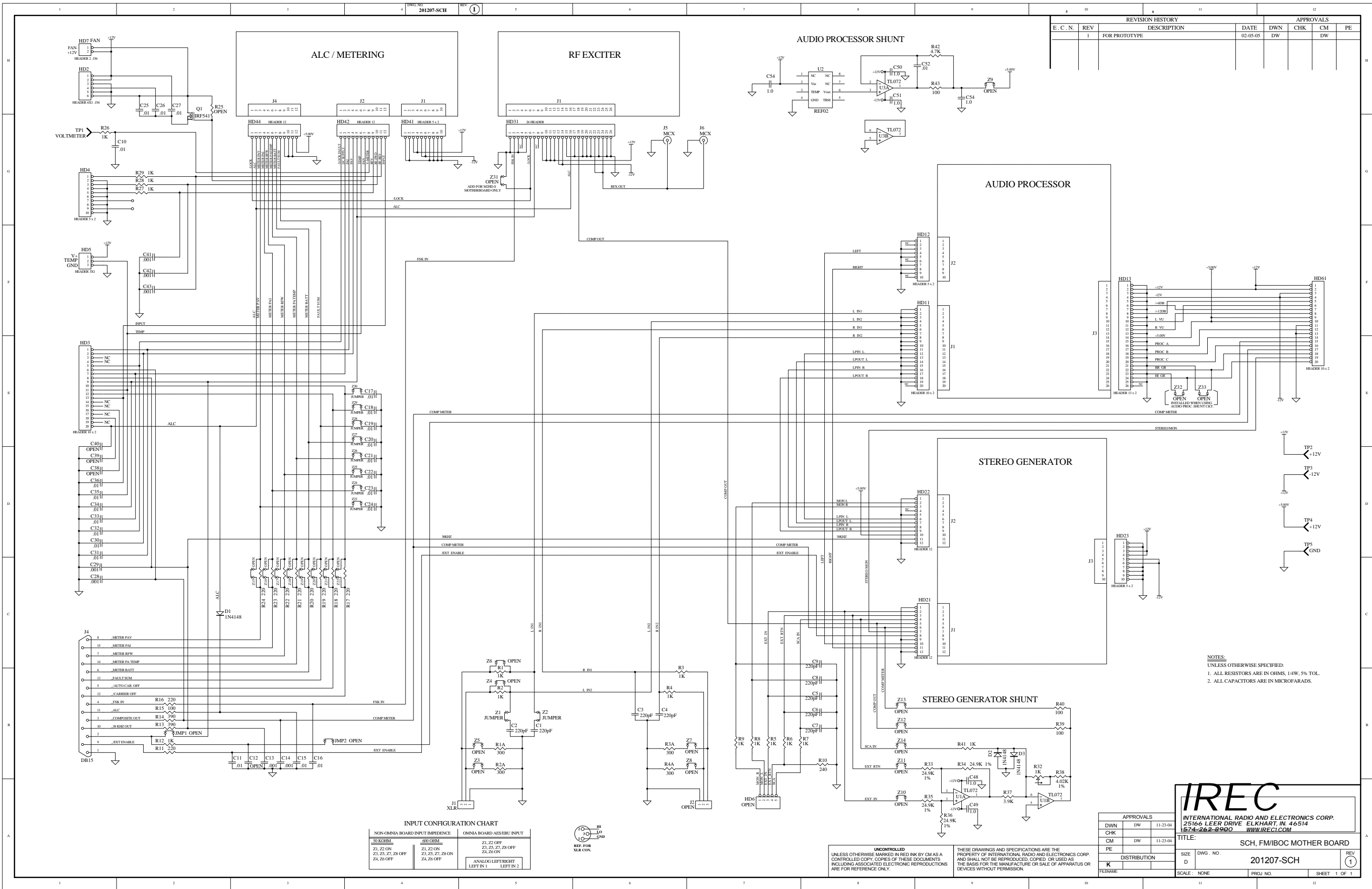

REVISION HISTORY				APPROVALS			
E. C. N.	REV	DESCRIPTION	DATE	DWN	CHK	CM	PE
	1	FOR PROTOTYPE	02-05-05	DW		DW	

INPUT CONFIGURATION CHART

NON-OMNIA BOARD INPUT IMPEDENCE		OMNIA BOARD AES/EBU INPUT	
NO OHMS	50 OHMS	Z1, Z2 OFF	Z1, Z2, Z3 OFF
Z1, Z2 ON	Z1, Z2 ON	Z1, Z2 ON	Z1, Z2, Z3 ON
Z3, Z5, Z7, Z8 OFF	Z3, Z5, Z7, Z8 ON	Z3, Z5, Z7, Z8 ON	Z3, Z5, Z7, Z8 ON
Z4, Z6 OFF	Z4, Z6 OFF	Z4, Z6 OFF	Z4, Z6 OFF

ANALOG LEFT/RIGHT LEFT IN 1 LEFT IN 2

NOTES:
 UNLESS OTHERWISE SPECIFIED:
 1. ALL RESISTORS ARE IN OHMS, 1/4W, 5% TOL.
 2. ALL CAPACITORS ARE IN MICROFARADS.

IREC
 INTERNATIONAL RADIO AND ELECTRONICS CORP.
 25166 LEER DRIVE ELKHART, IN 46514
 874-962-6900 WWW.IREC.COM

TITLE: SCH, FM/BOC MOTHER BOARD

APPROVALS

DWN	DW	11-23-01
CHK		
CM	DW	11-23-01
PE		

DISTRIBUTION

K	
---	--

SIZE DWG. NO. 201207-SCH
SCALE: NONE **PROJ. NO.:** **SHEET** 1 OF 1

UNCONTROLLED
 UNLESS OTHERWISE MARKED IN RED INK BY CM AS A CONTROLLED COPY, COPIES OF THESE DOCUMENTS INCLUDING ASSOCIATED ELECTRONIC REPRODUCTIONS ARE FOR REFERENCE ONLY.

THESE DRAWINGS AND SPECIFICATIONS ARE THE PROPERTY OF INTERNATIONAL RADIO AND ELECTRONICS CORP. AND SHALL NOT BE REPRODUCED, COPIED, OR USED AS THE BASIS FOR THE MANUFACTURE OR SALE OF APPARATUS OR DEVICES WITHOUT PERMISSION.

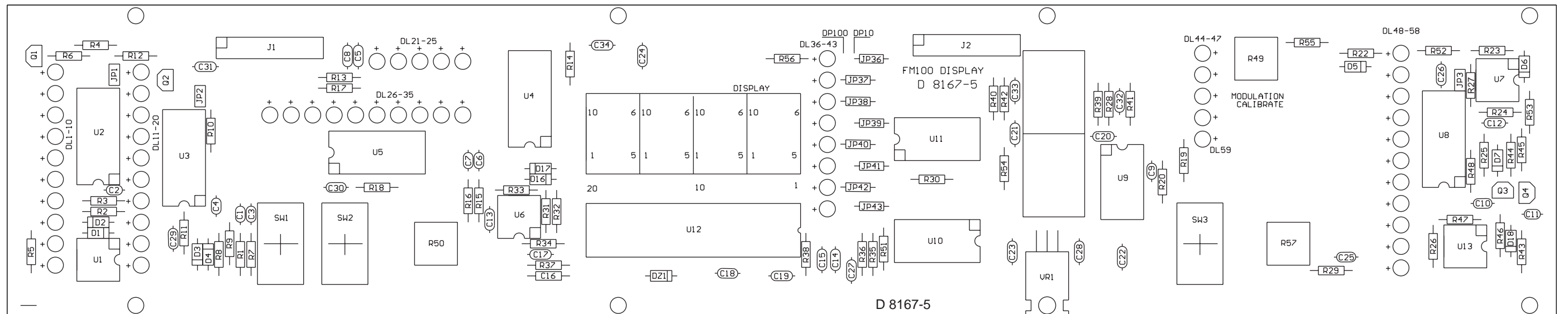
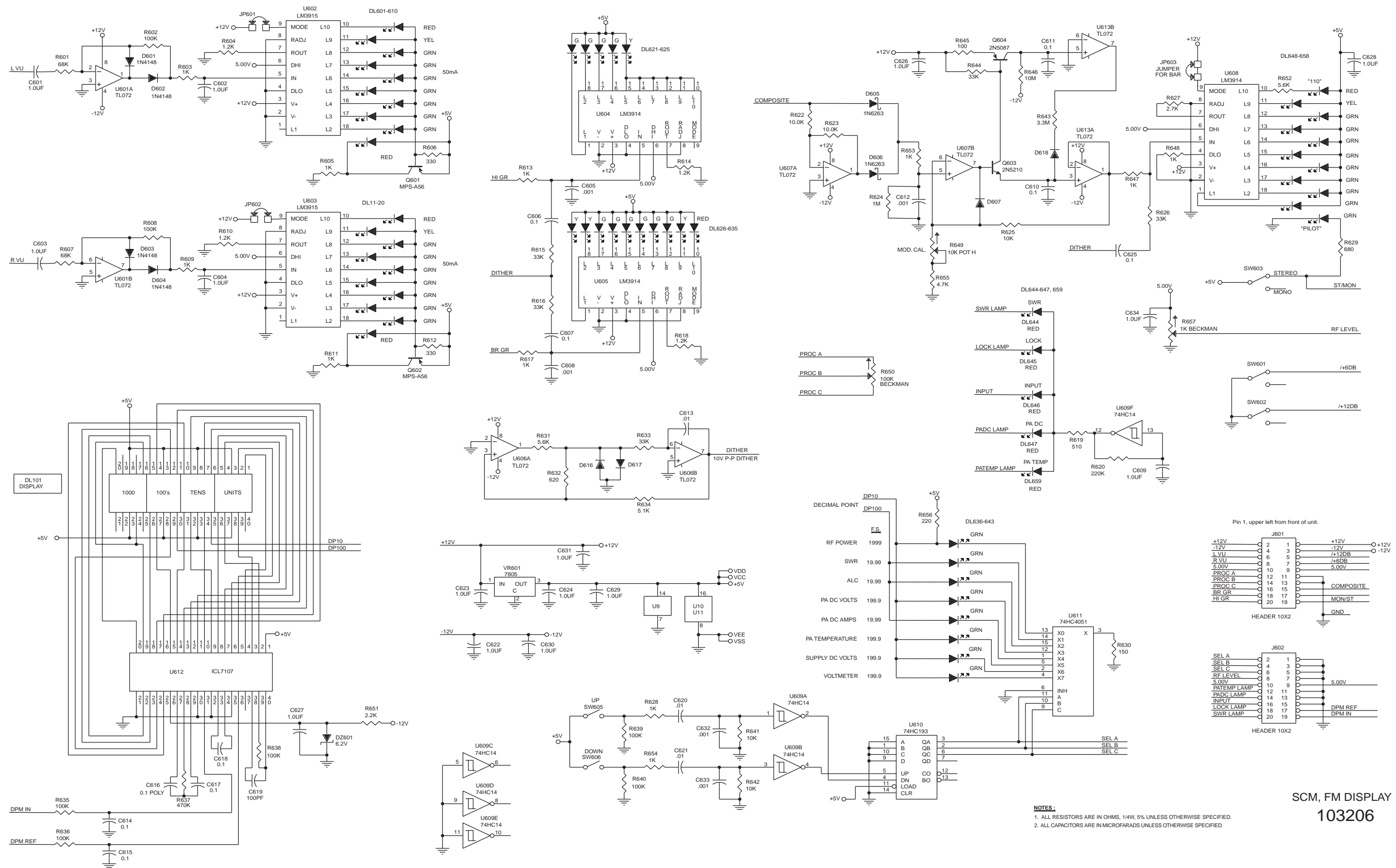
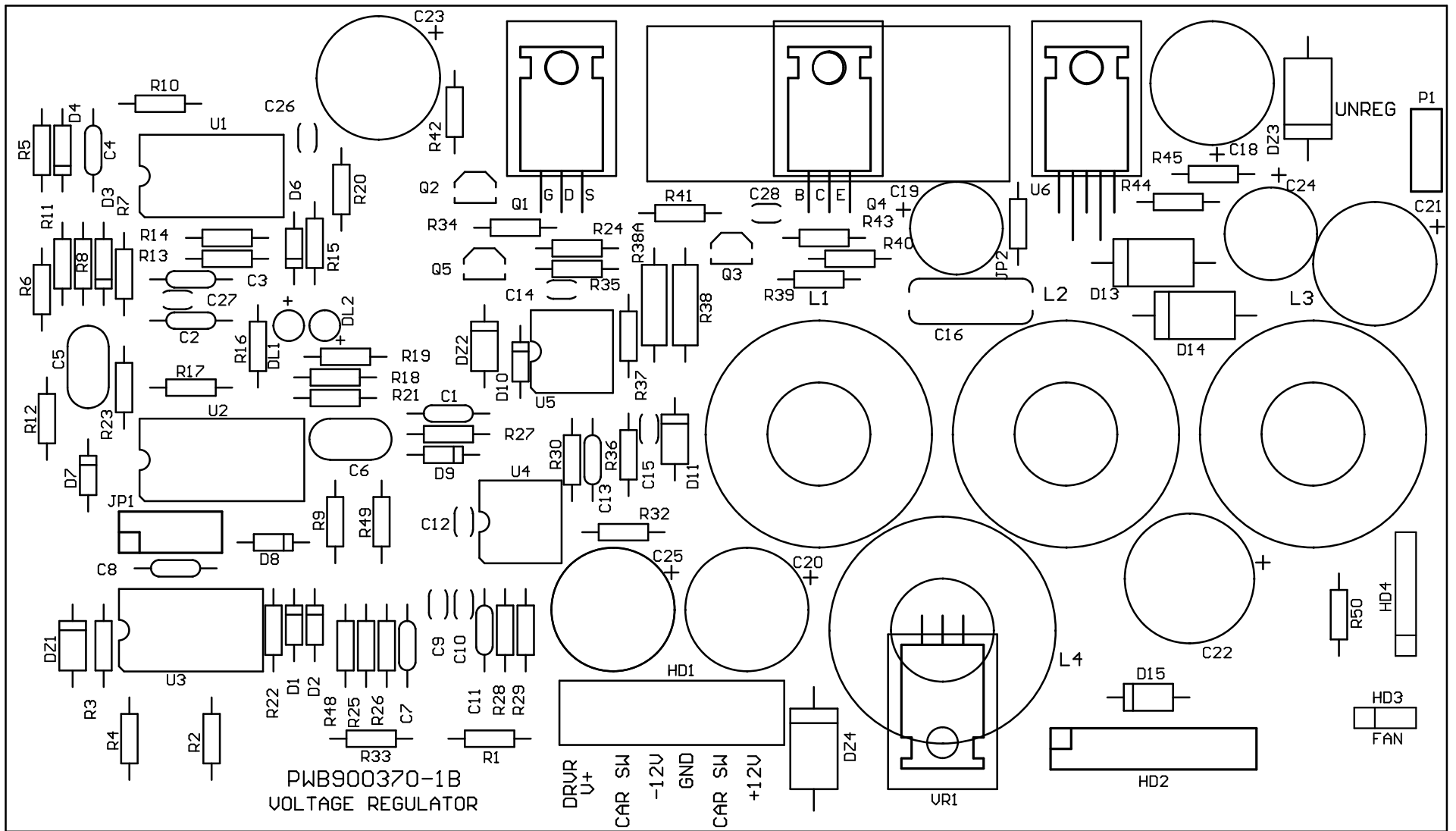

Illustration 6-10 Display Board



Schematic 6-6 Display

SCM, FM DISPLAY
103206



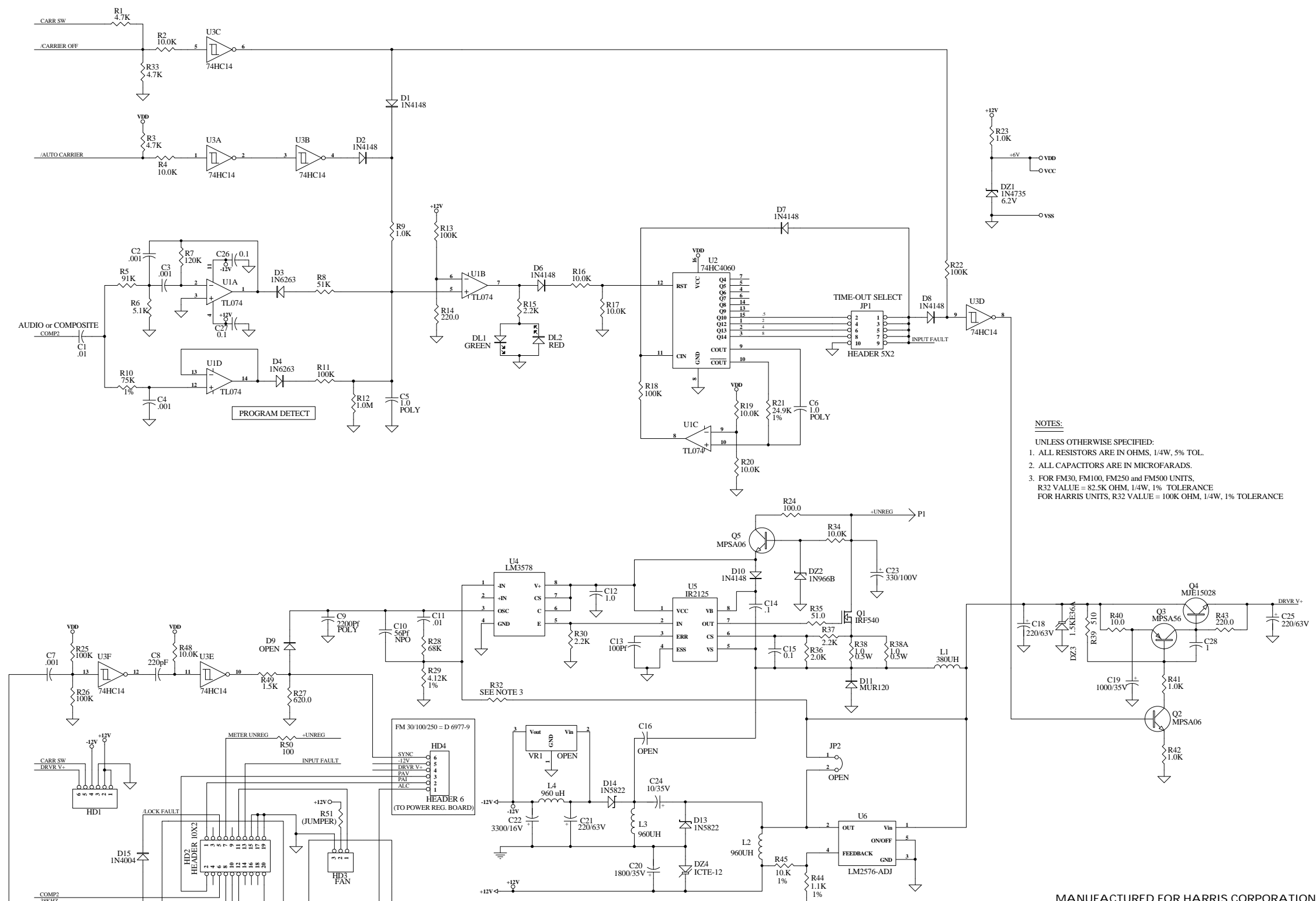

- NOTES:**
 UNLESS OTHERWISE SPECIFIED:
 1. ALL RESISTORS ARE IN OHMS, 1/4W, 5% TOL.
 2. ALL CAPACITORS ARE IN MICROFARADS.
 3. FOR FM30, FM100, FM250 and FM500 UNITS,
 R32 VALUE = 82.5K OHM, 1/4W, 1% TOLERANCE
 FOR HARRIS UNITS, R32 VALUE = 100K OHM, 1/4W, 1% TOLERANCE

MANUFACTURED FOR HARRIS CORPORATION

TITLE: SCH, FM30/100/250 VOLTAGE REGULATOR

SIZE C	DWG. NO. Q43229-6	REV AC
SCALE: NONE	PROJ. NO. 001,002,003	SHEET 11 OF 11

UNCONTROLLED
 UNLESS OTHERWISE MARKED IN RED INK BY CM AS A CONTROLLED COPY, COPIES OF THESE DOCUMENTS INCLUDING ASSOCIATED ELECTRONIC REPRODUCTIONS ARE FOR REFERENCE ONLY.

THESE DRAWINGS AND SPECIFICATIONS ARE THE PROPERTY OF INTERNATIONAL RADIO CORP. AND SHALL NOT BE REPRODUCED, COPIED OR USED AS THE BASIS FOR THE MANUFACTURE OR SALE OF APPARATUS OR DEVICES WITHOUT PERMISSION.

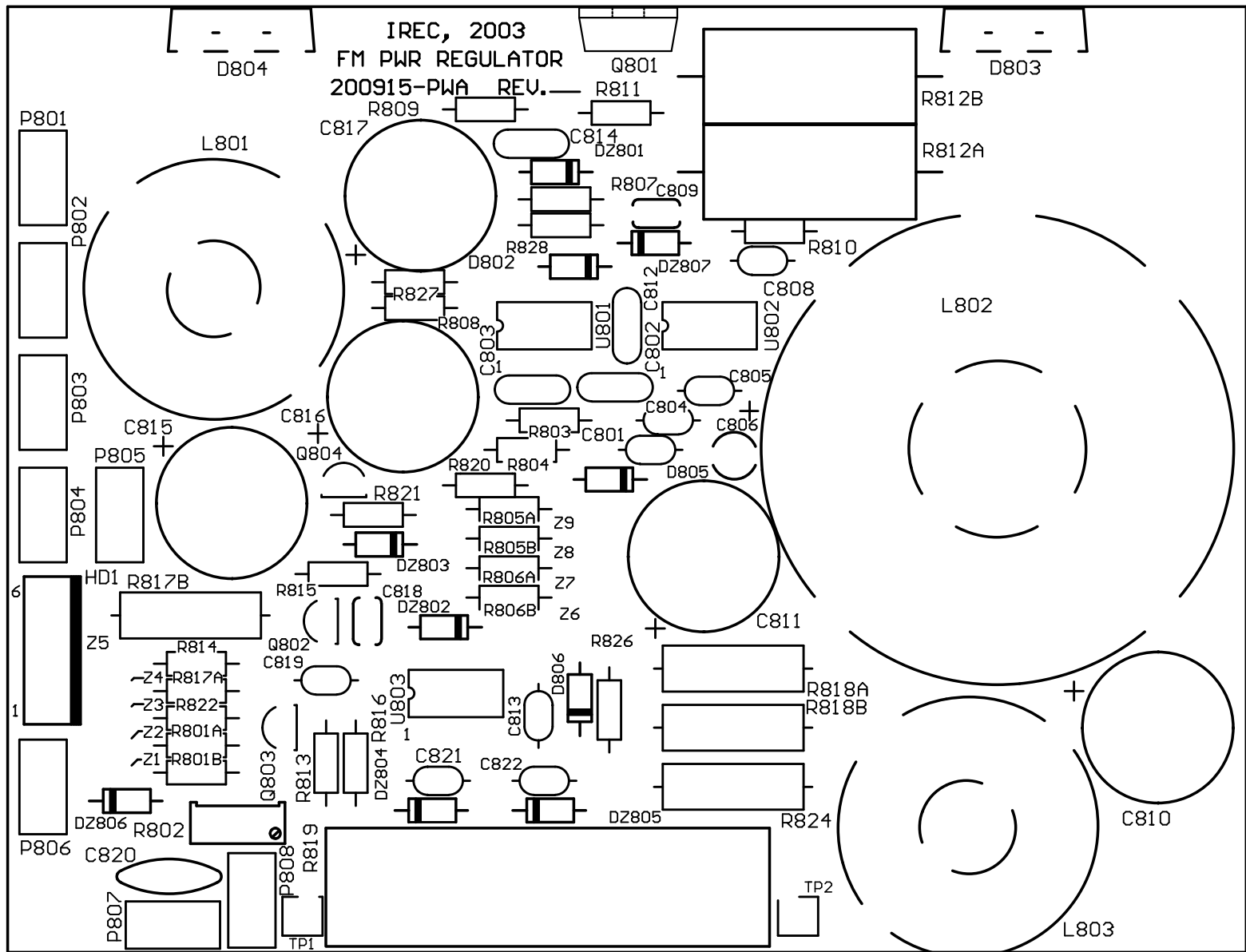

REVISION HISTORY				APPROVALS			
E. C. N.	REV	DESCRIPTION	DATE	DWN	CHK	CM	PE
	A	PRODUCTION RELEASE	10-31-03	DW		DW	DP
274	B	CORRECTED Z3 AND Z6 UNIT STATUS FOR M2 AND FM100	01-29-04	DW		DW	DP
323	C	SWAPPED Z1, Z2 TO MATCH PWB	08-10-04	DW		DW	DP

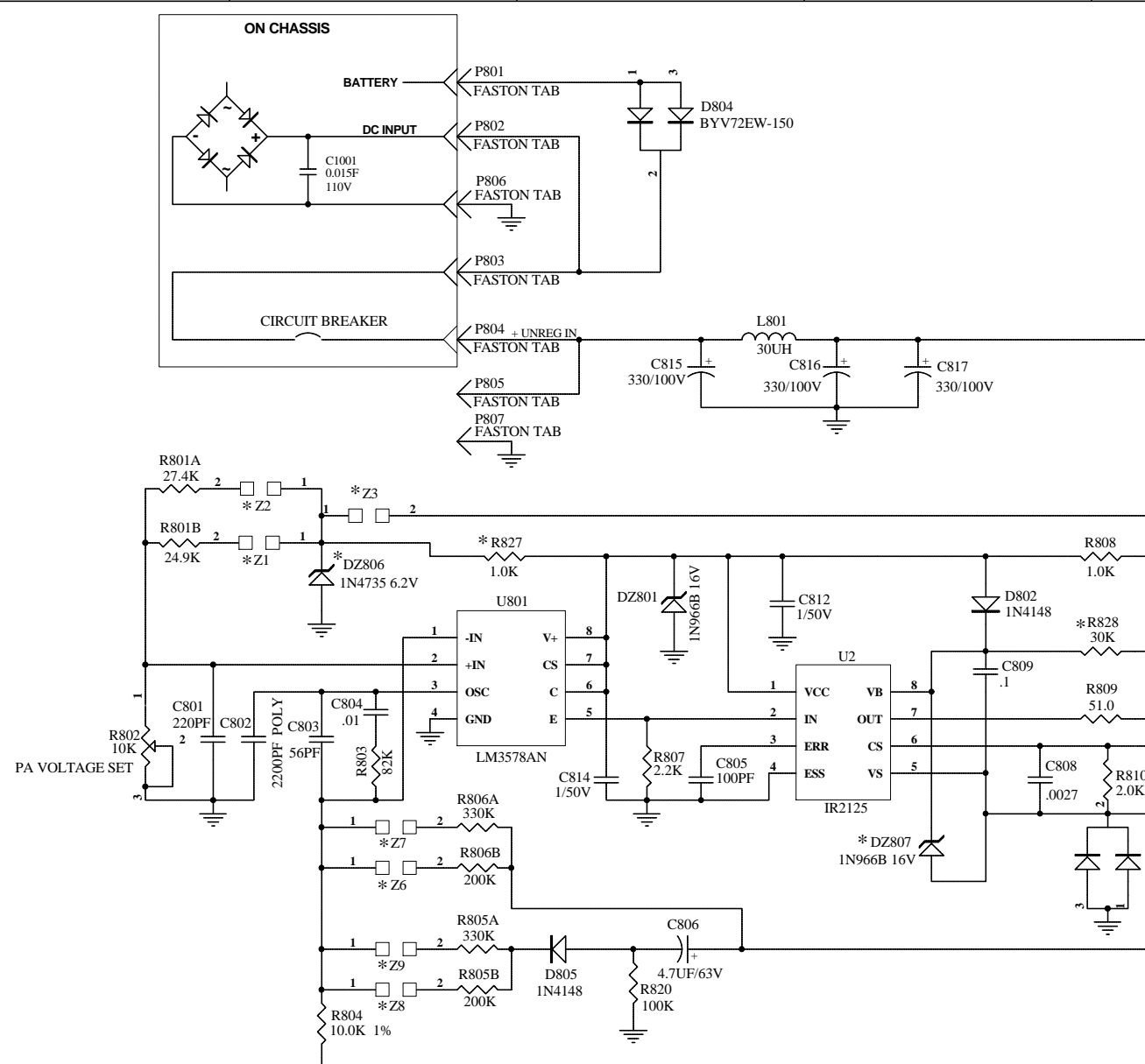

JUMPER	* UNIT CONFIGURATION							
	FM1	FM30	FM100	FM250	FM500	EURO	HARRIS M1	HARRIS M2
Z1	OPEN	OPEN	OPEN	OPEN	SHORT	OPEN	OPEN	SHORT
Z2	SHORT	SHORT	SHORT	SHORT	OPEN	SHORT	SHORT	OPEN
Z3	SHORT	SHORT	SHORT	SHORT	SHORT	SHORT	OPEN	OPEN
Z8	SHORT	SHORT	OPEN	OPEN	OPEN	OPEN	OPEN	OPEN
Z7	OPEN	OPEN	SHORT	SHORT	SHORT	SHORT	SHORT	SHORT
Z6	SHORT	SHORT	OPEN	OPEN	OPEN	OPEN	OPEN	OPEN
Z4	SHORT	SHORT	SHORT	SHORT	OPEN	SHORT	SHORT	OPEN
Z5	OPEN	OPEN	OPEN	OPEN	SHORT	OPEN	OPEN	SHORT
Z9	OPEN	OPEN	SHORT	SHORT	SHORT	SHORT	SHORT	SHORT

- NOTES:**
- UNLESS OTHERWISE SPECIFIED:**
- ALL RESISTORS ARE IN OHMS, 1/4W, 5% TOL.
 - ALL CAPACITORS ARE IN MICROFARADS.

REF DES	H43608-1	H43395-5	H43533-1	H43533-1	H43533-1	H43533-1	H43533-1	H43533-1
L802								
R811	3.3K	3.3K	3.3K	3.3K	3.3K	5.11K 1%	3.3K	3.3K
R827	OPEN	OPEN	OPEN	OPEN	OPEN	OPEN	INSTALLED	INSTALLED
R828	OPEN	OPEN	OPEN	OPEN	OPEN	OPEN	INSTALLED	INSTALLED
DZ806	OPEN	OPEN	OPEN	OPEN	OPEN	OPEN	INSTALLED	INSTALLED
DZ807	OPEN	OPEN	OPEN	OPEN	OPEN	OPEN	INSTALLED	INSTALLED

IREC
INTERNATIONAL RADIO AND ELECTRONICS CORP.
 25166 LEER DRIVE ELKHART, IN. 46514
 574-262-8900 WWW.IREC1.COM

APPROVALS		
DWN	DW	09-30-03
CHK		
CM	DW	09-30-03
PE	DP	09-30-03
DISTRIBUTION		
FILENAME:	200915-SCH	

TITLE: SCH, FM POWER REGULATOR		REV. C
SIZE B	DWG. NO. 200915-SCH	
SCALE: NONE	PROJ NO. 533	SHEET 1 OF 1

UNCONTROLLED
 UNLESS OTHERWISE MARKED IN RED INK BY CM AS A CONTROLLED COPY, COPIES OF THESE DOCUMENTS INCLUDING ASSOCIATED ELECTRONIC REPRODUCTIONS ARE FOR REFERENCE ONLY.

THESE DRAWINGS AND SPECIFICATIONS ARE THE PROPERTY OF INTERNATIONAL RADIO AND ELECTRONICS CORP. AND ARE NOT TO BE REPRODUCED, COPIED OR USED AS THE BASIS FOR THE MANUFACTURE OR SALE OF APPARATUS OR DEVICES WITHOUT PERMISSION.

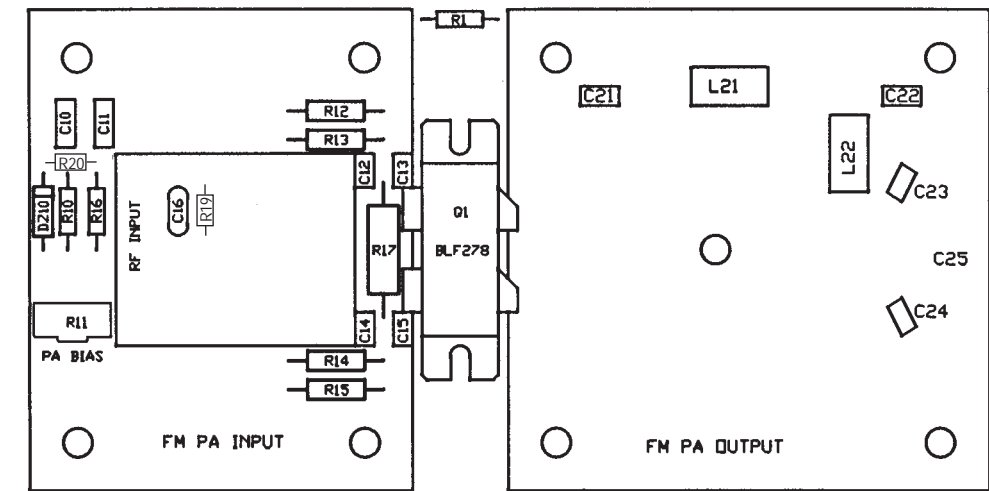
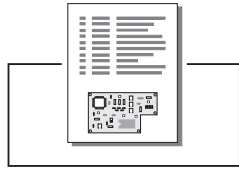

Illustration 6-13 Power Amplifier-FM100/FM250

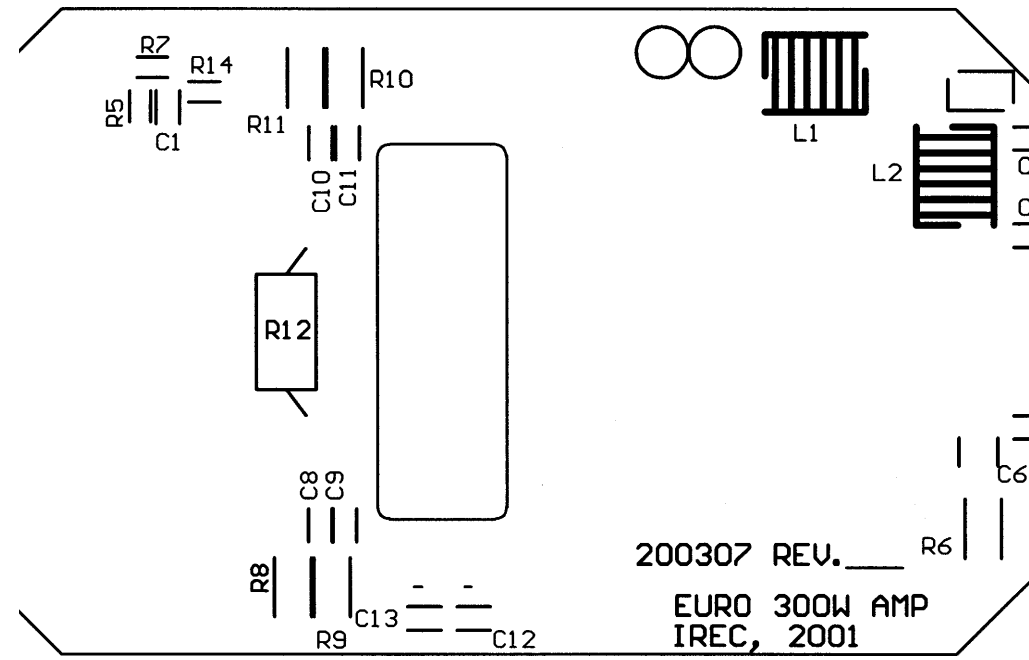
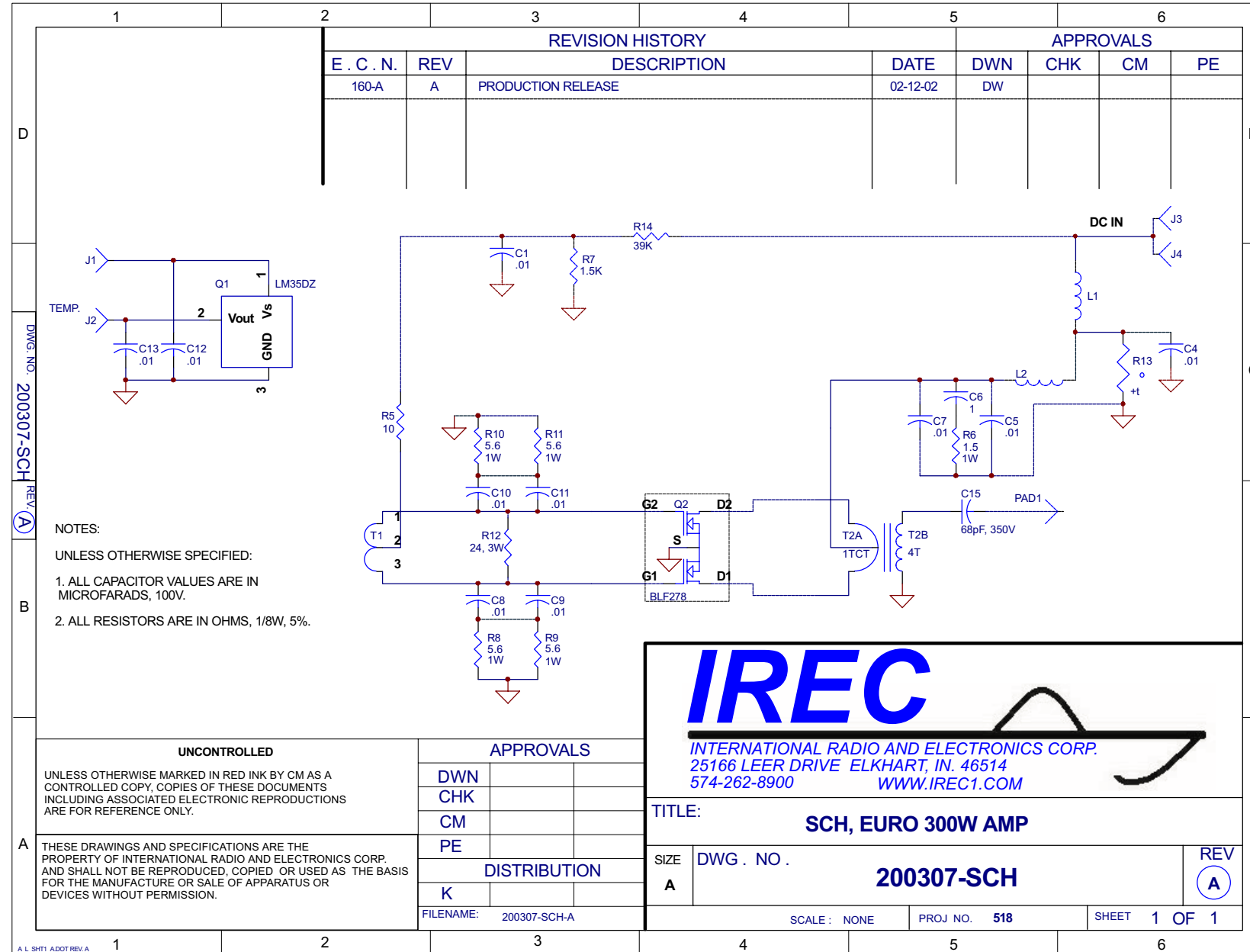
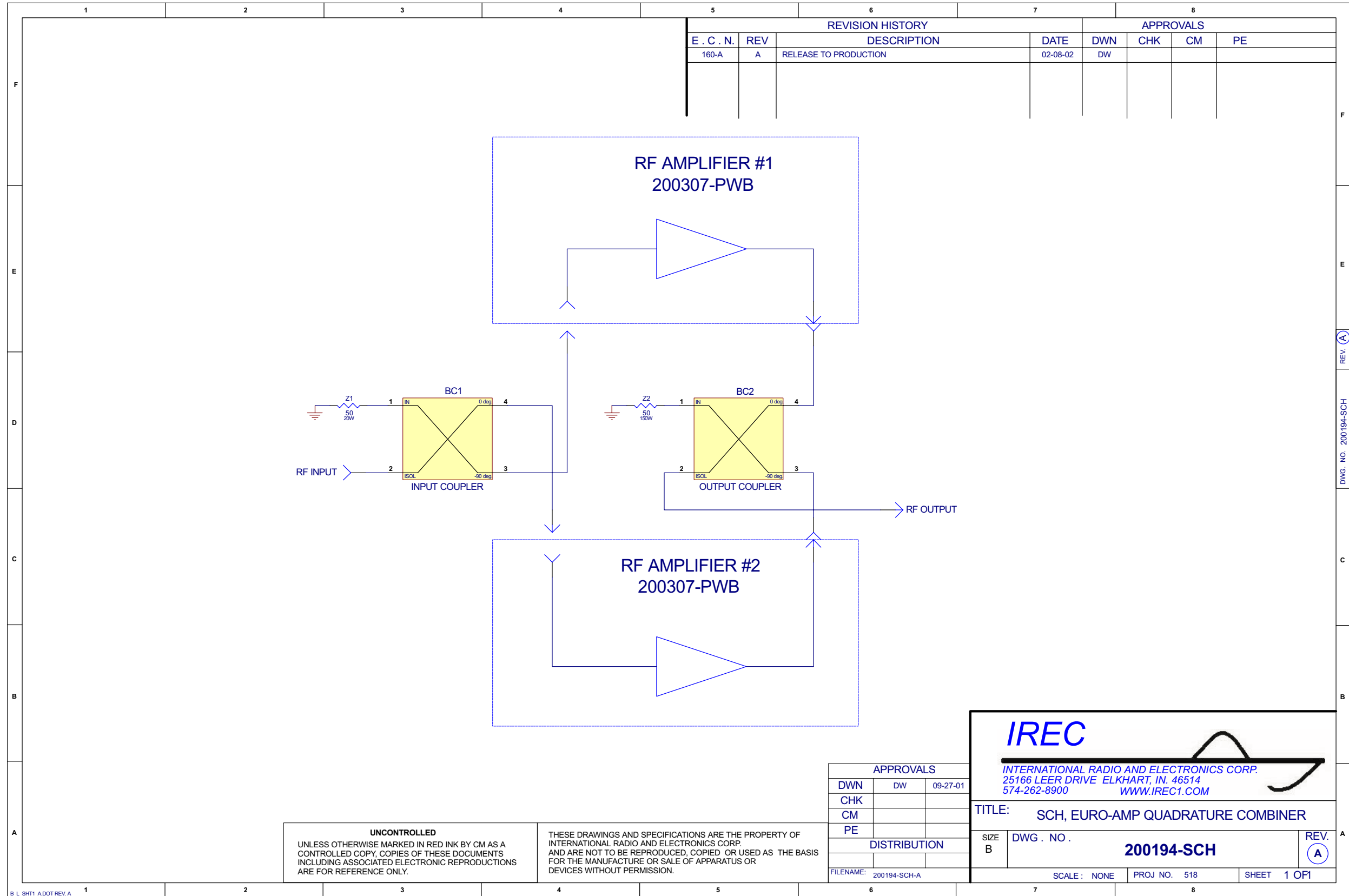

Illustration 6-13 Power Amplifier



Schematic 6-9 RF Output Amplifier



Schematic 6-10 Quadrature Power Combiner

		REVISION HISTORY			APPROVALS															
	E. C. N.	REV	DESCRIPTION	DATE	DWN	CHK														
	160-A	A	PRODUCTION RELEASE	02-20-02	DWN															
D						D														
B	<p>NOTES:</p> <p>1. ALL CAPACITORS ARE IN PICOFARADS.</p> <p>2. ALL RESISTORS ARE IN OHMS, 1W, 5%.</p>					B														
A	<p>UNCONTROLLED</p> <p>UNLESS OTHERWISE MARKED IN RED INK BY CM AS A CONTROLLED COPY, COPIES OF THESE DOCUMENTS INCLUDING ASSOCIATED ELECTRONIC REPRODUCTIONS ARE FOR REFERENCE ONLY.</p>		<p style="text-align:center;">APPROVALS</p> <table border="1" style="width:100%; border-collapse: collapse;"> <tr> <td style="text-align:center;">DWN</td> <td style="text-align:center;">DWN</td> <td style="text-align:center;">02-19-02</td> </tr> <tr> <td style="text-align:center;">CHK</td> <td></td> <td></td> </tr> <tr> <td style="text-align:center;">CM</td> <td></td> <td></td> </tr> <tr> <td style="text-align:center;">PE</td> <td></td> <td></td> </tr> </table>			DWN	DWN	02-19-02	CHK			CM			PE			<p>INTERNATIONAL RADIO AND ELECTRONICS CORP. 25166 LEER DRIVE ELKHART, IN. 46514 574-262-8900 WWW.IREC1.COM</p>		A
DWN	DWN	02-19-02																		
CHK																				
CM																				
PE																				
		<p>THESE DRAWINGS AND SPECIFICATIONS ARE THE PROPERTY OF INTERNATIONAL RADIO AND ELECTRONICS CORP. AND SHALL NOT BE REPRODUCED, COPIED OR USED AS THE BASIS FOR THE MANUFACTURE OR SALE OF APPARATUS OR DEVICES WITHOUT PERMISSION.</p>			<p>TITLE: SCH, FM250 EURO POWER AMP RF INPUT</p>															
		<p style="text-align:center;">DISTRIBUTION</p> <table border="1" style="width:100%; border-collapse: collapse;"> <tr> <td style="text-align:center;">K</td> <td></td> <td></td> </tr> </table>			K			<p>SIZE A DWG. NO. 200305-SCH REV A</p>												
K																				
		<p>FILENAME: 200305-SCH-A</p>			<p>SCALE: NONE PROJ. NO. 518 SHEET 1 OF 1</p>															
1	2	3	4	5	6															

Schematic 6-11 RF Input

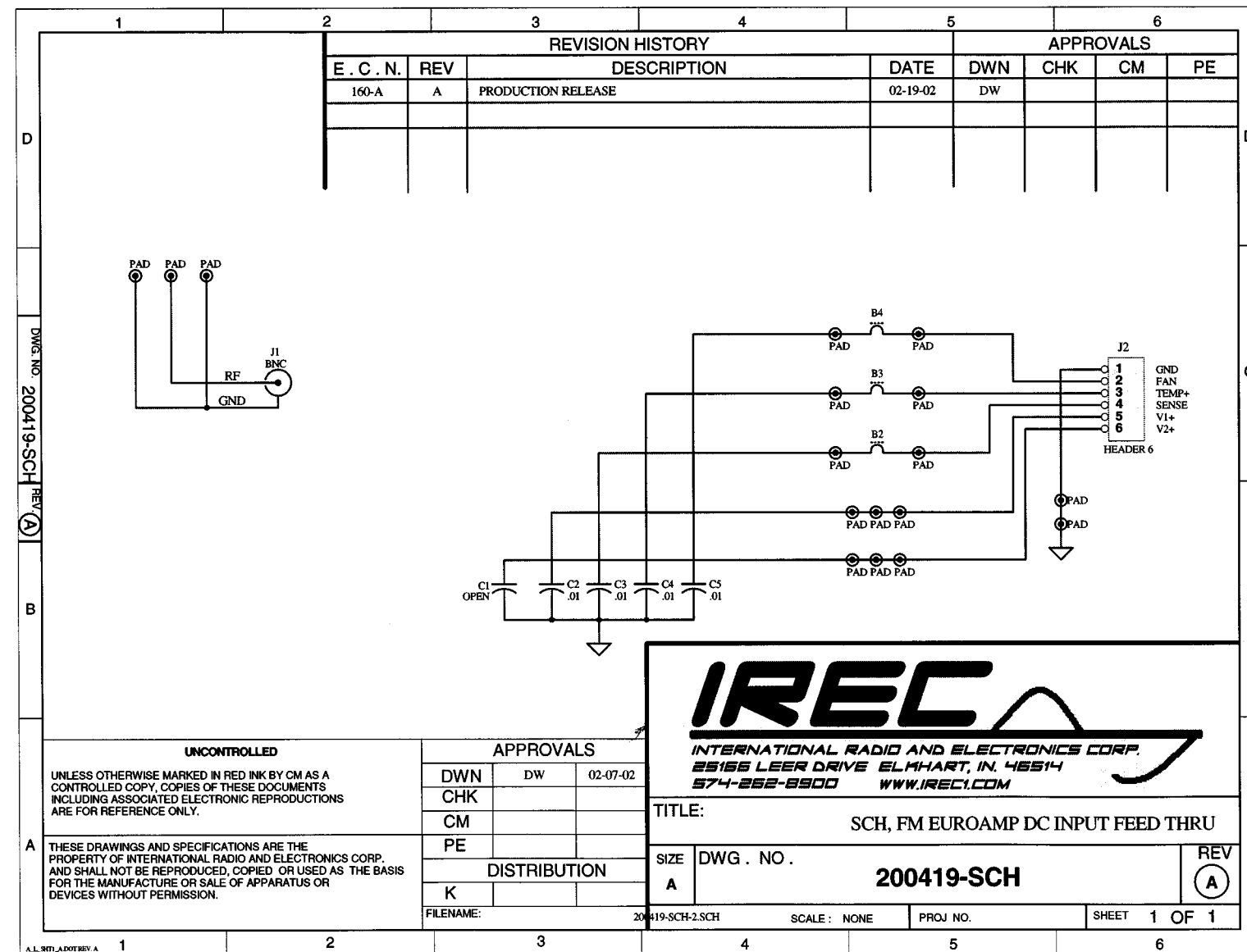

Schematic 6-12 DC Input

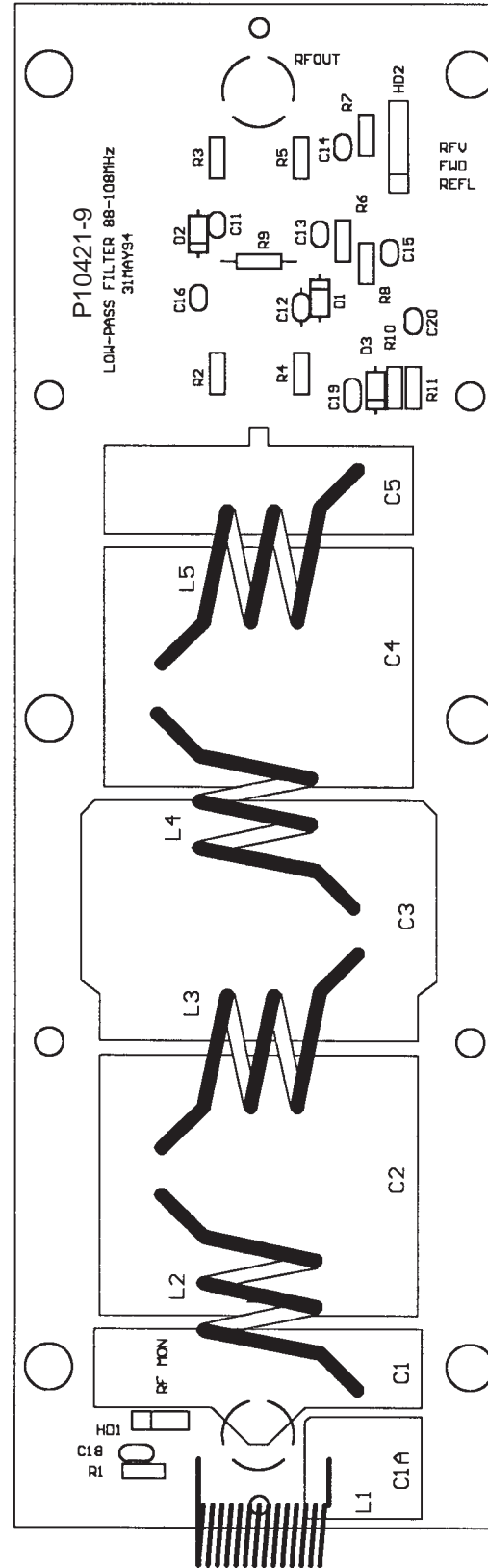
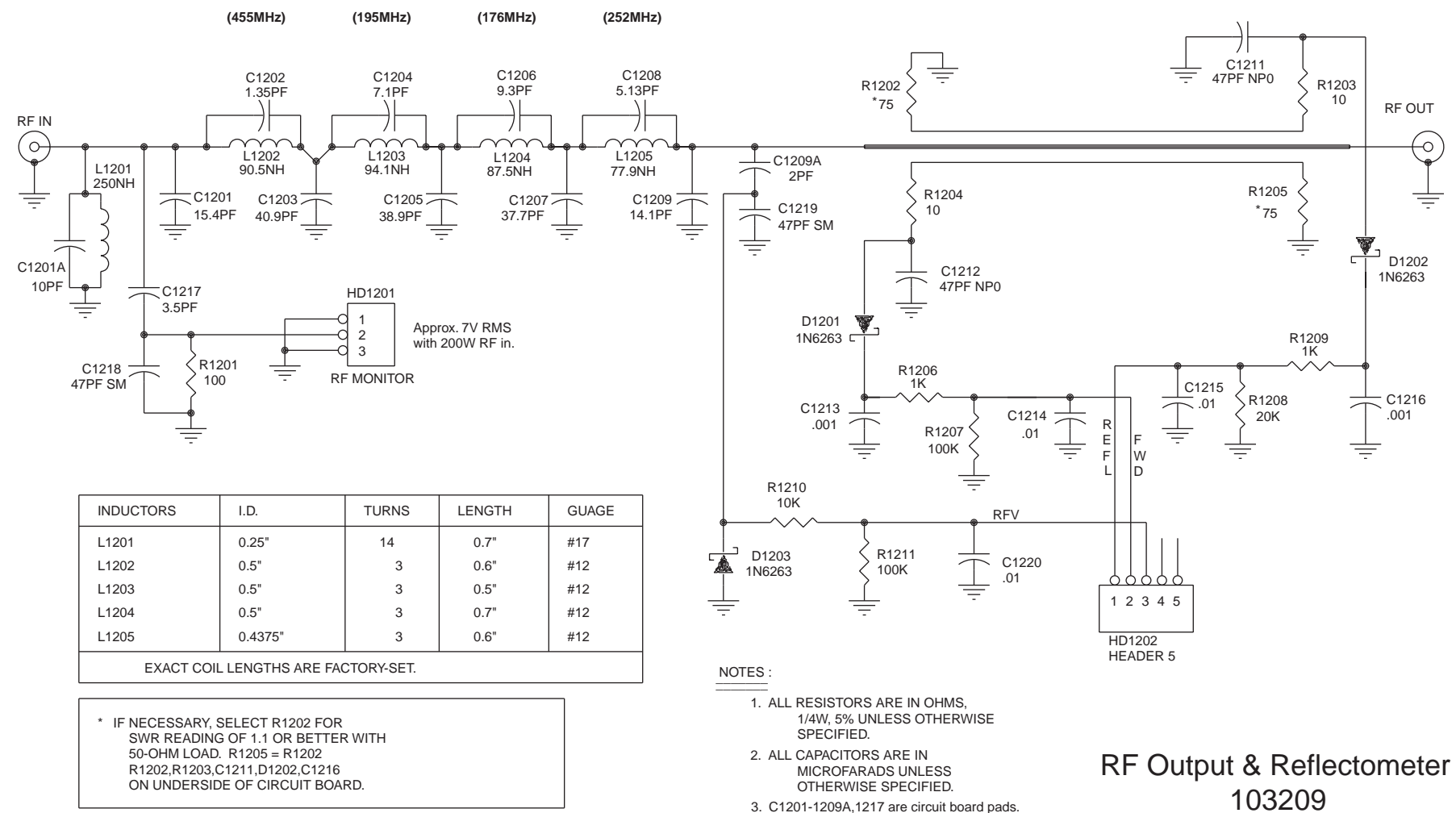
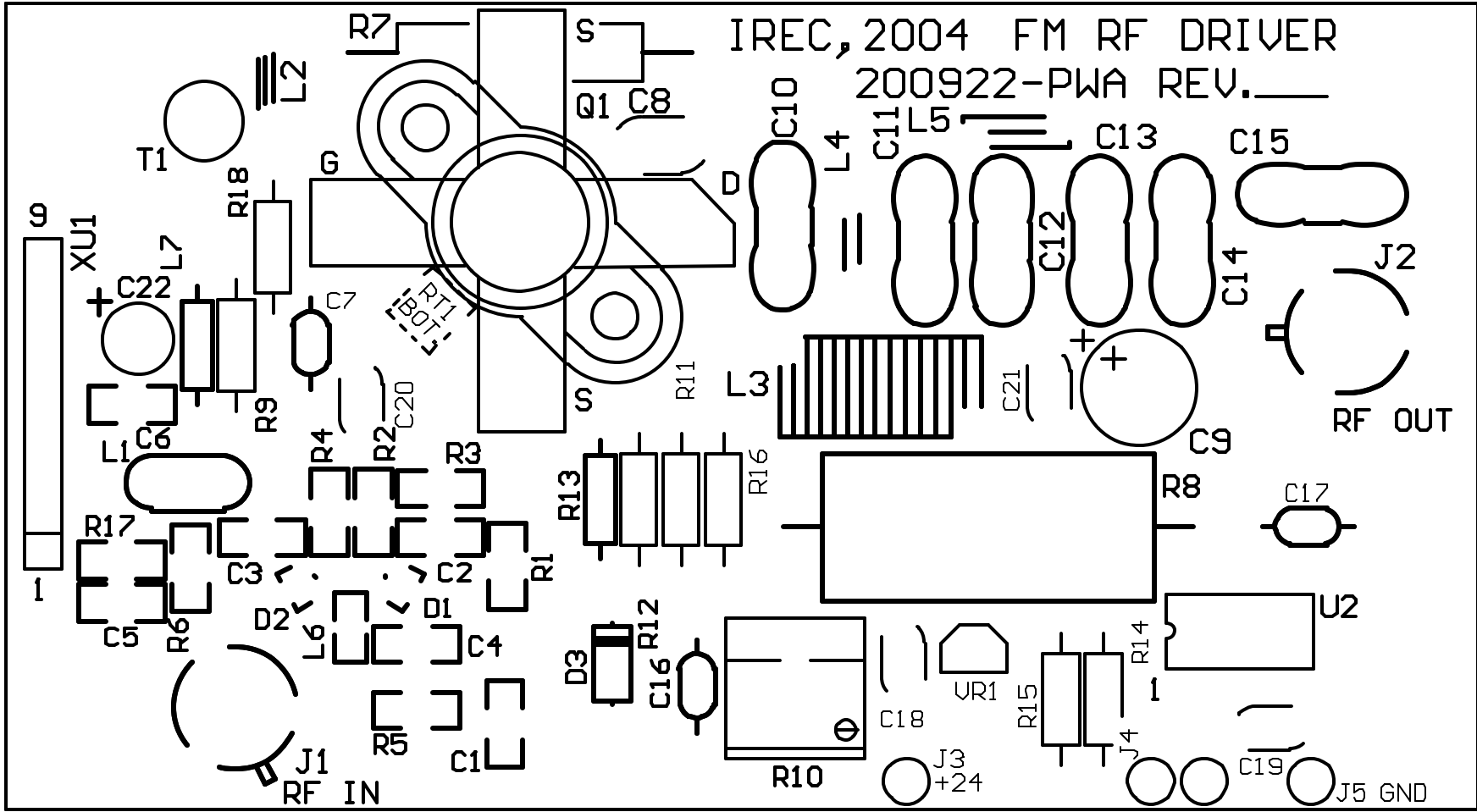
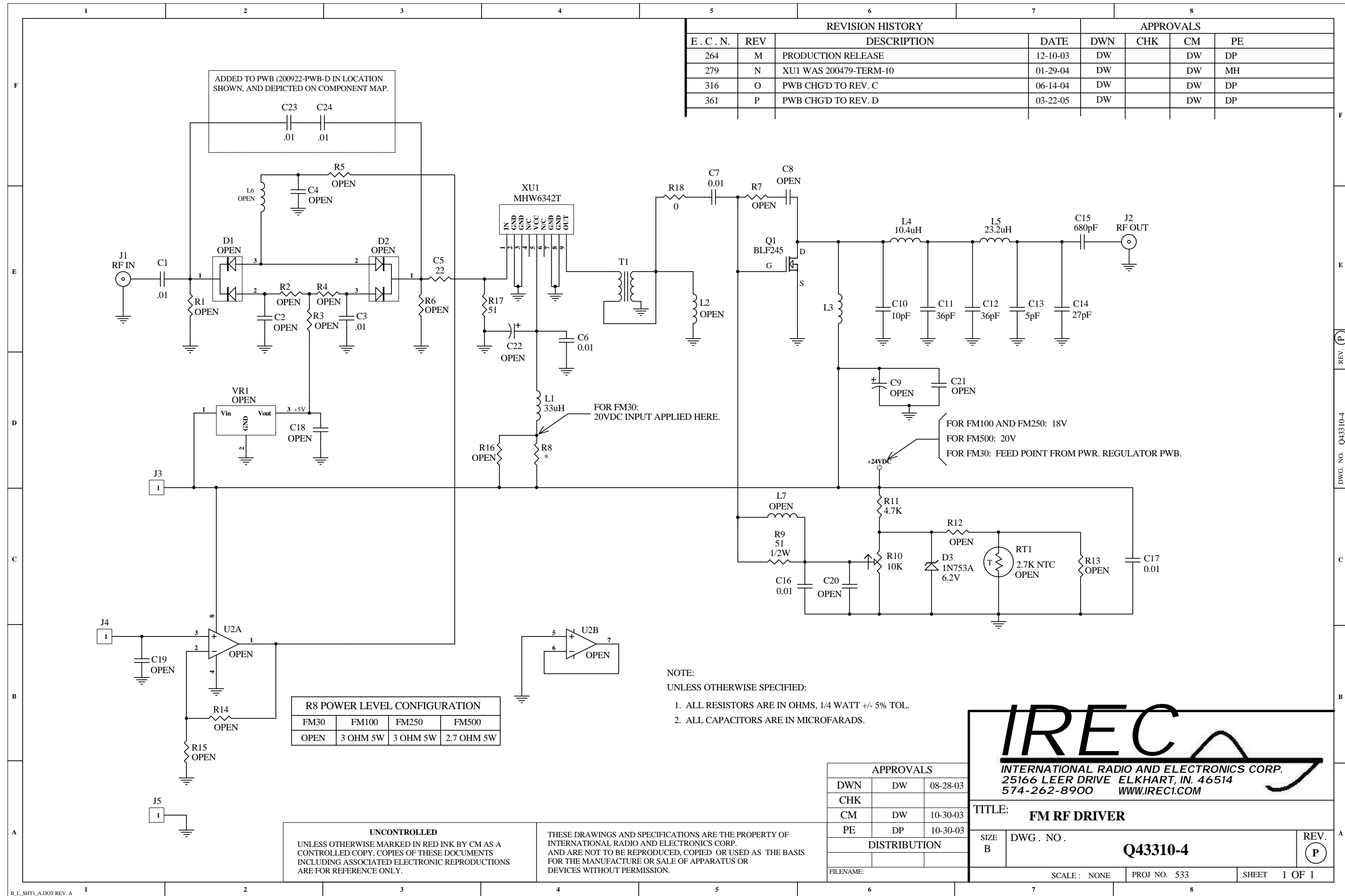

Illustration 6-14 RF Output Filter



Schematic 6-13 RF Output Filter and Reflectometer





REVISION HISTORY				APPROVALS			
E. C. N.	REV	DESCRIPTION	DATE	DWN	CHK	CM	PE
264	M	PRODUCTION RELEASE	12-10-03	DW		DW	DP
279	N	XU1 WAS 200479-TERM-10	01-29-04	DW		DW	MH
316	O	PWB CHG'D TO REV. C	06-14-04	DW		DW	DP
361	P	PWB CHG'D TO REV. D	03-22-05	DW		DW	DP

IREC
INTERNATIONAL RADIO AND ELECTRONICS CORP.
25166 LEER DRIVE ELKHART, IN. 46514
574-262-8900 WWW.IREC1.COM

TITLE: **FM RF DRIVER**

APPROVALS
DWN DW 08-28-03
CHK
CM DW 10-30-03
PE DP 10-30-03

DISTRIBUTION

FILENAME: SCALE: NONE PROJ NO. 533 SHEET 1 OF 1

SIZE B DWG. NO. **Q43310-4** REV. **P**

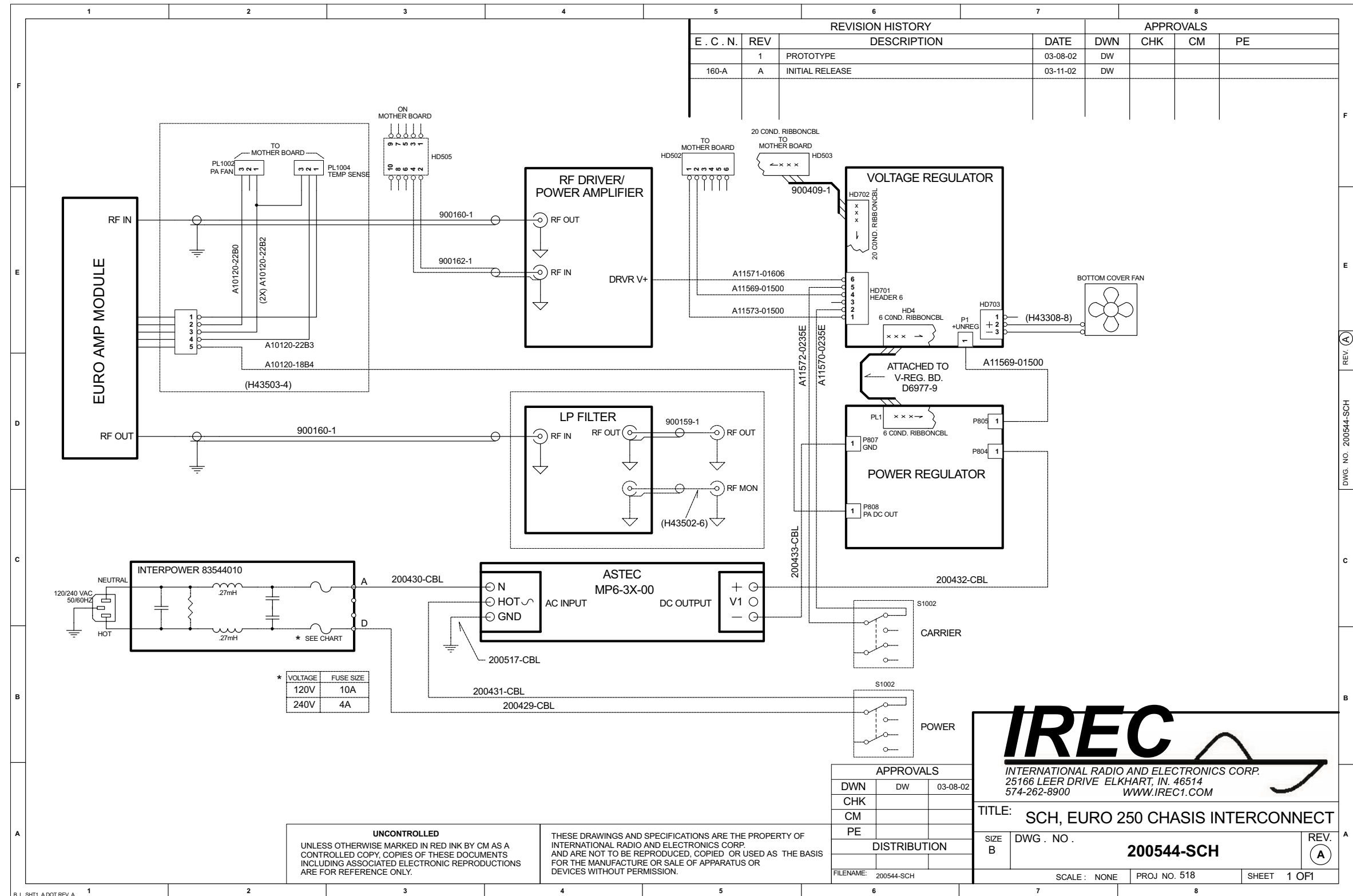

Schematic 6-15 Chassis Wiring

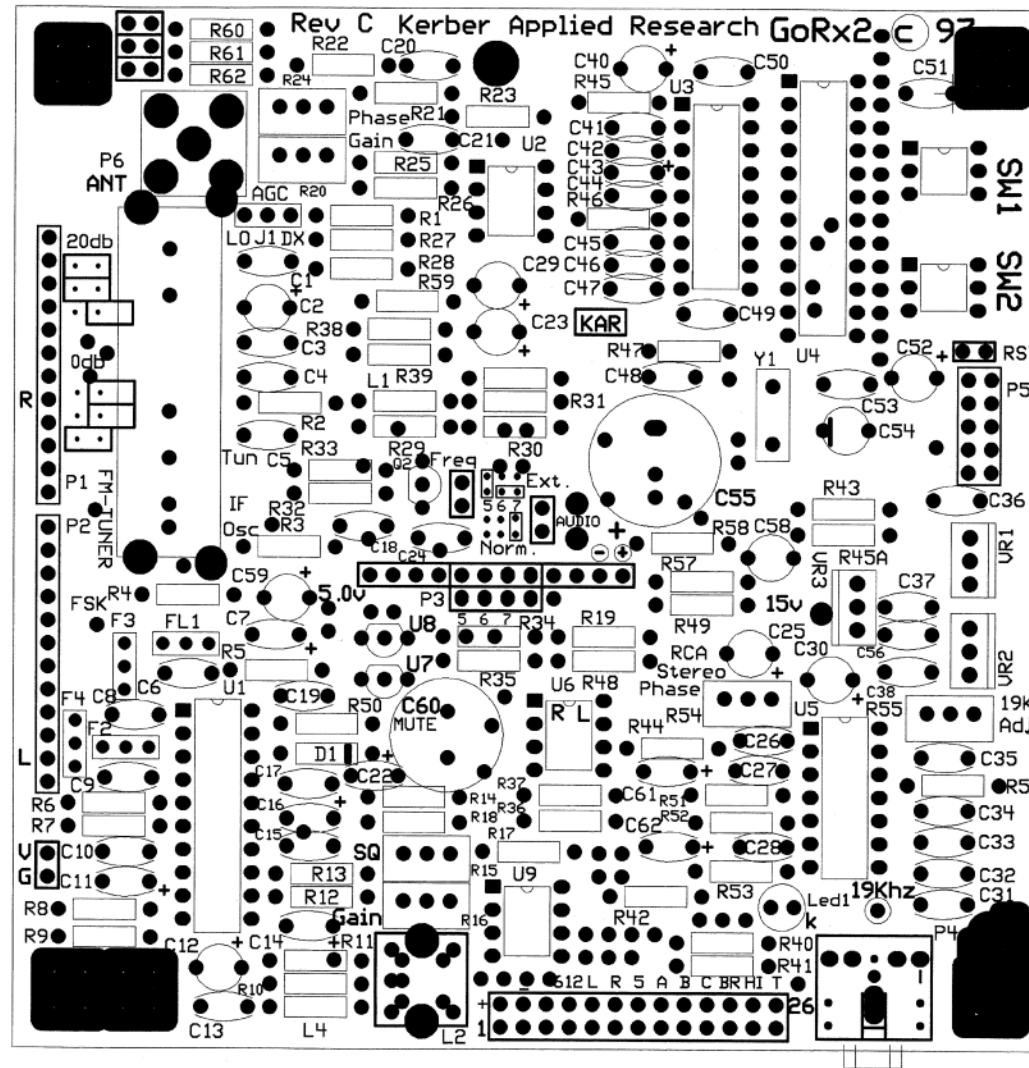
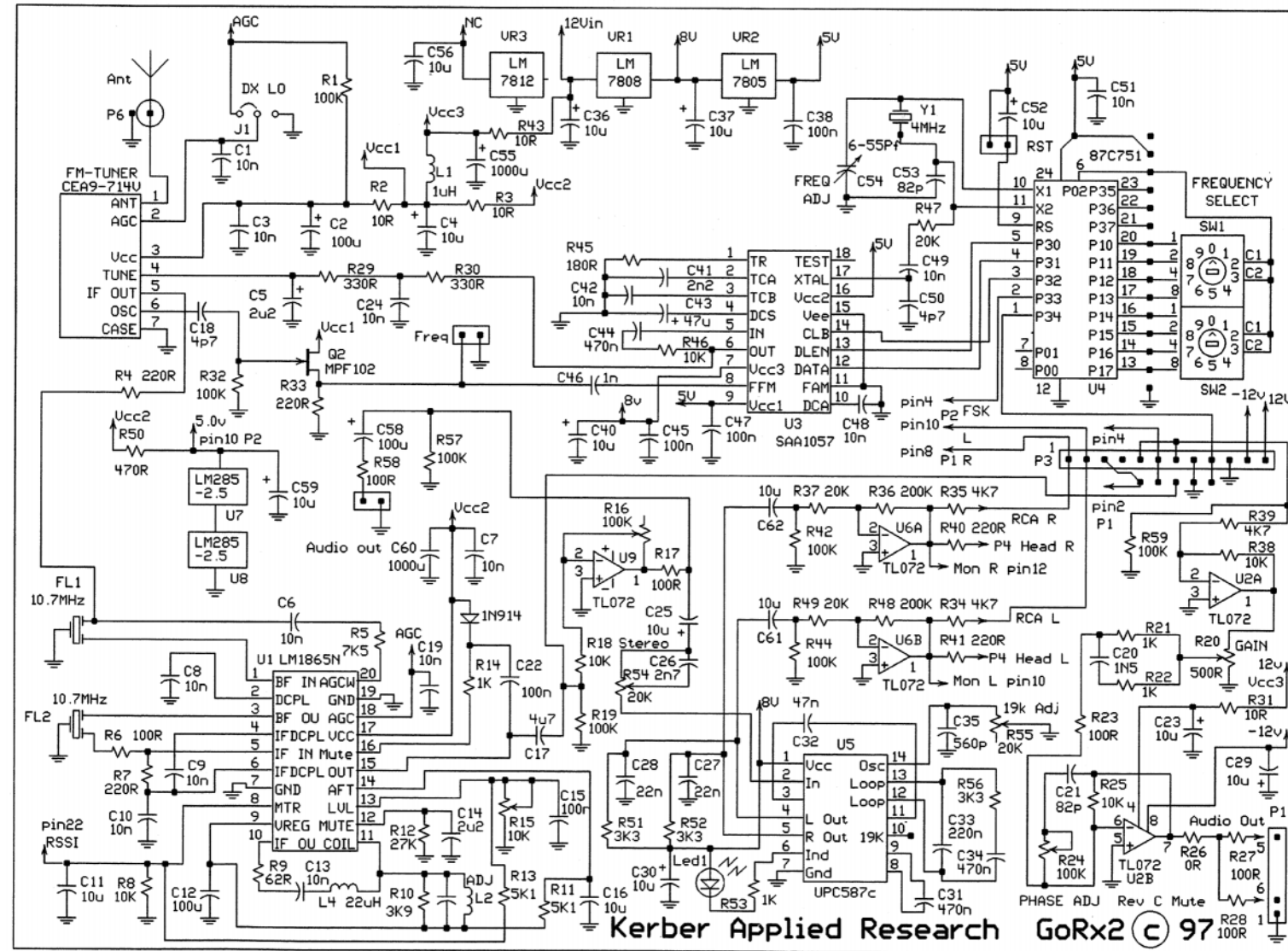

Illustration 6-16 Receiver Board



Schematic 6-16 Receiver Board



Section 7—Service and Support

We understand that you may need various levels of support or that the product could require servicing at some point in time. This section provides information for both of these scenarios.

7.1 Service

The product warranty (see opposite page) outlines our responsibility for defective products. Before returning a product for repair or replacement (our choice), call our Customer Service department using the following telephone number:

(866) 262-8917

Our Customer Service Representative will give you further instructions regarding the return of your product. Use the original shipping carton or a new one obtained from Crown. Place shipping spacers between the slide-out power amplifier assembly and the back panel. Please fill out the Factory Service Instructions sheet (page 7–5) and include it with your returned product.

7.2 24-Hour Support

In most instances, what you need to know about your product can be found in this manual. There are times when you may need more in-depth information or even emergency-type information. We provide 24-hour technical assistance on your product via a toll telephone call. For **emergency help** or **detailed technical assistance**, call

(866) 262-8917

You may be required to leave a message at this number but your call will be returned promptly from our on-call technician.

7.3 Spare Parts

To obtain spare parts, call **Crown Broadcast Service** at the following number.

(866) 262-8917

You may also write to the following address:

International Radio & Electronics Corporation

25166 Leer Drive

Elkhart, Indiana, U.S.A. 46514-5425

Three-Year Limited Warranty

North America Only

SUMMARY OF WARRANTY

We, Crown Broadcast, a business unit of International Radio and Electronics Company, Inc., 25166 Leer Drive, Elkhart, Indiana 46515-2000 warrant to the ORIGINAL PURCHASER of a NEW Crown Broadcast product, for a period of three (3) years from the date of purchase by the original purchaser (the "warranty period") that the new Crown Broadcast product is free of defects in materials and workmanship and will meet or exceed all advertised specifications for such a product. This warranty does not extend to any subsequent purchaser or user, and automatically terminates upon sale or other disposition of our product.

ITEMS EXCLUDED FROM THIS CROWN BROADCAST

We are not responsible for product failure caused by misuse, accident, or neglect. This warranty does not extend to any product on which the serial number has been defaced, altered, or removed. It does not cover damage to loads or any other products or accessories resulting from Crown Broadcast product failure. It does not cover defects or damage caused by use of unauthorized modifications, accessories, parts, or service.

WHAT WE WILL DO

We will remedy any defect, in material or workmanship (except as excluded), in our sole discretion, by repair, replacement, or refund. If a refund is elected, then you must make the defective or malfunctioning component available to us free and clear of all liens or other encumbrances. The refund will be equal to the actual purchase price, not including interest, insurance, closing costs, and other finance charges less a reasonable depreciation on the product from the date of original purchase. Warranty work can only be performed at our authorized service centers or at our factory. Expenses in remedying the defect will be borne by Crown Broadcast, including two-way surface freight shipping costs within the United States. (Purchaser must bear the expense of shipping the product between any foreign country and the port of entry in the United States and all taxes, duties, and other custom's fee(s) for such foreign shipments.)

HOW TO OBTAIN WARRANTY SERVICE

You must notify us of your need for warranty service not later than ninety (90) days after the expiration of the warranty period. We will give you an authorization to return the product for service. All components must be shipped in a factory pack or equivalent which, if needed, may be obtained from us for a nominal charge. Corrective actions will be taken within a reasonable time of the date of receipt of the defective product by us. If the repairs made by us are not satisfactory, notify us immediately.

DISCLAIMER OF CONSEQUENTIAL AND INCIDENTAL DAMAGES

You are not entitled to recover from us any consequential or incidental damages resulting from any defect in our product. This includes any damage to another product or products resulting from such a defect.

WARRANTY ALTERATIONS

No person has the authority to enlarge, amend, or modify this warranty. The warranty is not extended by the length of time for which you are deprived of the use of the product. Repairs and replacement parts are provided under the terms of this warranty shall carry only the unexpired portion of this warranty.

DESIGN CHANGES

We reserve the right to change the design of any product from time to time without notice and with no obligation to make corresponding changes in products previously manufactured.

LEGAL REMEDIES OF PURCHASER

There is no warranty which extends beyond the terms hereof. This written warranty is given in lieu of any oral or implied warranties not contained herein. We disclaim all implied warranties, including without limitation any warranties of merchantability or fitness for a particular purpose. No action to enforce this warranty shall be commenced later than ninety (90) days after expiration of the warranty period.

Crown Broadcast, International and Radio Company, Inc.
25166 Leer Drive, P.O. Box 2000, Elkhart, Indiana 46515-2000
Phone: (574) 262-8900; FAX: (574) 262-5399

Factory Service Instructions

To obtain factory service, complete the bottom half of this page, include it with the unit, and ship to:

**International Radio & Electronics Corporation
25166 Leer Drive
Elkhart, Indiana, U.S.A. 46514-5425**

For units in warranty (within 5 years of purchase from any authorized Crown Dealer): We pay for ground UPS shipments from anywhere in the continental U.S. and Federal Express Second Day service from Hawaii and Alaska to the factory and back to you. Expedited service/shipment is available for an additional charge. You may forward your receipt for shipping charges which we will reimburse. We do not cover any charges for shipping outside the U.S. or any of the expenses involved in clearing customs.

If you have any questions about your Crown Broadcast product, please contact Crown Broadcast Customer Service at:

Telephone: (866) 262-8917 or (866) 262-8972
Fax: (866) 262-8909

Name: _____ Company: _____

Shipping Address: _____

Phone Number: Fax: _____

Model: _____ Serial Number: _____ Purchase Date: _____

Nature of the Problem

(Describe the conditions that existed when the problem occurred and what attempts were made to correct it.)

Other equipment in your system: _____

If warranty has expired, payment will be: Cash/Check VISA Mastercard
 Please Quote before servicing

Card Number: _____ Exp. Date: _____ Signature: _____

Return Shipment Preference if other than UPS Ground: Expedite Shipment Other _____

ENCLOSE WITH UNIT—DO NOT MAIL SEPARATELY